

DENNIS

RAZOR 560 & RAZOR ULTRA 560

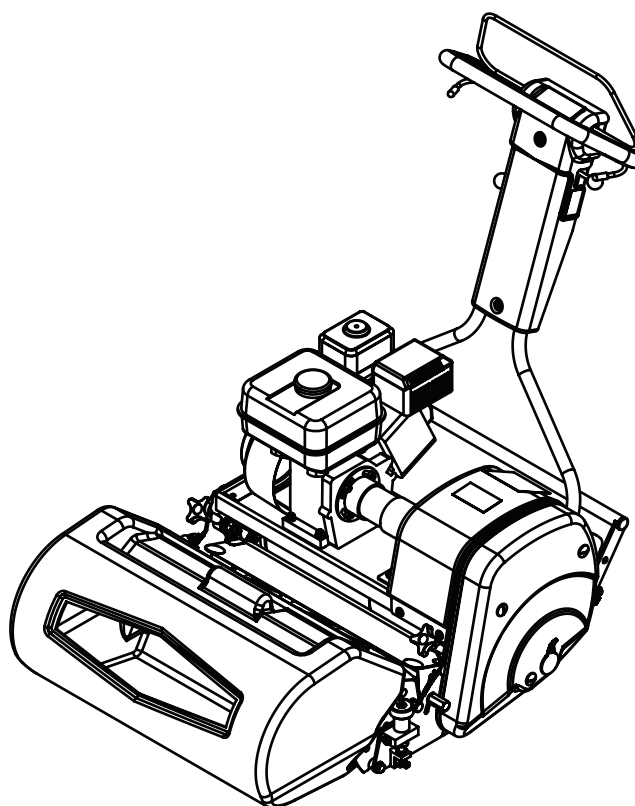

INSTRUCTION MANUAL

DENNIS, Ashbourne Road, Kirk Langley, Derby, DE6 4NJ, United Kingdom

Telephone:- 01332 824777

Fax:- 01332 824 525

E-mail:- sales@dennisuk.com

E-mail:- spares@dennisuk.com

www.dennisuk.com

SP20002_REV_1
10/12

Product Application Matrix

Application	FT	Razor Range	Razor 560	Simplex Ultra 560	G560 Range	SuperSix: G680	G660/G760 Range	Premier G860	Contractor Range	Bray Hand	S500 Tools	Gang Plus	Mower
Bowling Green		✓	✓	✓			✓			✓	✓	✓	
Cricket Ground Maintenance: square	wicket	✓	✓	✓						✓	✓	✓	
Cricket Ground Maintenance: outfield	✓				✓	✓	✓	✓					
Football Pitch							✓	✓				✓	✓
Golf Course Maintenance: Greens	Tees	✓			✓	✓	✓	✓		✓	✓		
Golf Course Maintenance: Greens	✓	✓	✓						✓	✓	✓		
Ornamental	✓			✓	✓	✓	✓						
Croquet Green		✓	✓	✓	✓		✓	✓		✓		✓	
Grass Tennis Court		✓	✓	✓			✓			✓	✓	✓	
Race Course Maintenance: Ornamental	Parade Ring	✓			✓	✓	✓	✓	✓	✓			✓
Rugby Pitch							✓	✓				✓	
Hockey Pitch							✓	✓					
Sports Club Maintenance		✓	✓	✓	✓	✓	✓	✓	✓	✓	✓	✓	✓
Schools, Colleges & University Grounds		✓	✓	✓	✓	✓	✓	✓	✓	✓	✓	✓	✓
Cemetery Maintenance				✓	✓	✓	✓						
Contractors, Private Lawns & Commercial	✓	✓			✓	✓	✓	✓		✓			✓
Local Authority & Government Contracts	✓	✓	✓	✓	✓	✓	✓	✓	✓	✓	✓	✓	✓
Ornamental Lawn	✓	✓			✓	✓	✓	✓	✓	✓			✓



NOTE

THIS INFORMATION IS INTENDED FOR GUIDANCE PURPOSES ONLY. WE RECOMMEND THAT YOU DISCUSS YOUR SPECIFIC REQUIREMENT WITH OUR HEAD OFFICE, SALES MANAGERS OR YOUR LOCAL DENNIS DEALER.

Certificate of Conformity

Cylinder mowers powered by Honda GX Petrol Engine

Manufacturer:- Howardson Ltd, Howardson Works, Kirk Langley, Derby, DE6 4NJ. UK

Owner of Technical Document:- Mr I.D. Howard, Howardson Ltd, Howardson Works Kirk Langley, Derby, DE6 4NJ, UK

Notified Body:- AV Technology Ltd, AVTECH house, Arkle Avenue, Stanley Green Trading Estate, Handforth, Cheshire, SK9 3RW, UK

I the under signed Declare that these machines:-

Model	Cutting Width	Power (Honda)	Measured Sound Power Level	Guaranteed Sound Power Level	Serial Number
Razor Ultra 560	22" (560mm)	GX120	91dB Lwa	94dB Lwa	See Product ID range

Tested at:- Howardson Works test site September 2011

Complies with the applicable requirements of:-

- Machine Directive 2006/42/EC
- Noise Directive 2000/14/EC (Annex VI Procedure 1)

Managing Director



Ian Howard

Serial Numbers



NOTE

MAKE A NOTE OF THE SERIAL NUMBERS OF YOUR MACHINE & ENGINE AND ALWAYS QUOTE THEM IN ANY COMMUNICATION WITH PERSONNEL AT DENNIS.

MACHINE SERIAL NUMBER

ENGINE SERIAL NUMBER

Introduction

The reliability and quality of performance of this machine depends upon some simple care maintenance carried out regularly. This manual has been prepared to allow the user to carry out all such work.

It is advisable to read the instructions carefully. Proper care and attention will enable the machine to give a continuous, satisfactory, and reliable service. Failure to carry out regular lubrication and maintenance as outlined in this manual may render any guarantee or warranty invalid.

In the case of any difficulty, or if further information or advice is required, our Service Department is always at your call. In the interests of speed and accuracy of information please quote the serial numbers of the machine and engine when making enquiries.

For the mower, this is to be found on a plate attached to the engine deck. The engine number is stamped on either the crank case or the gear casing facing towards the front of the machine. We suggest you write the numbers on the front page of this book.

	Page
Product Application Matrix.....	2
Declaration of Conformity.....	3
Serial Numbers.....	3
Introduction.....	3
Technical Data.....	4
Machine Description.....	5
Important Safety Instructions.....	6
Controls.....	7
Operating Instructions.....	8 - 9
General Adjustments.....	10 - 12
Routine Maintenance.....	13 - 14
Storage.....	14
General Lubrication.....	15
Parts Listings.....	16 - 33

Technical Data

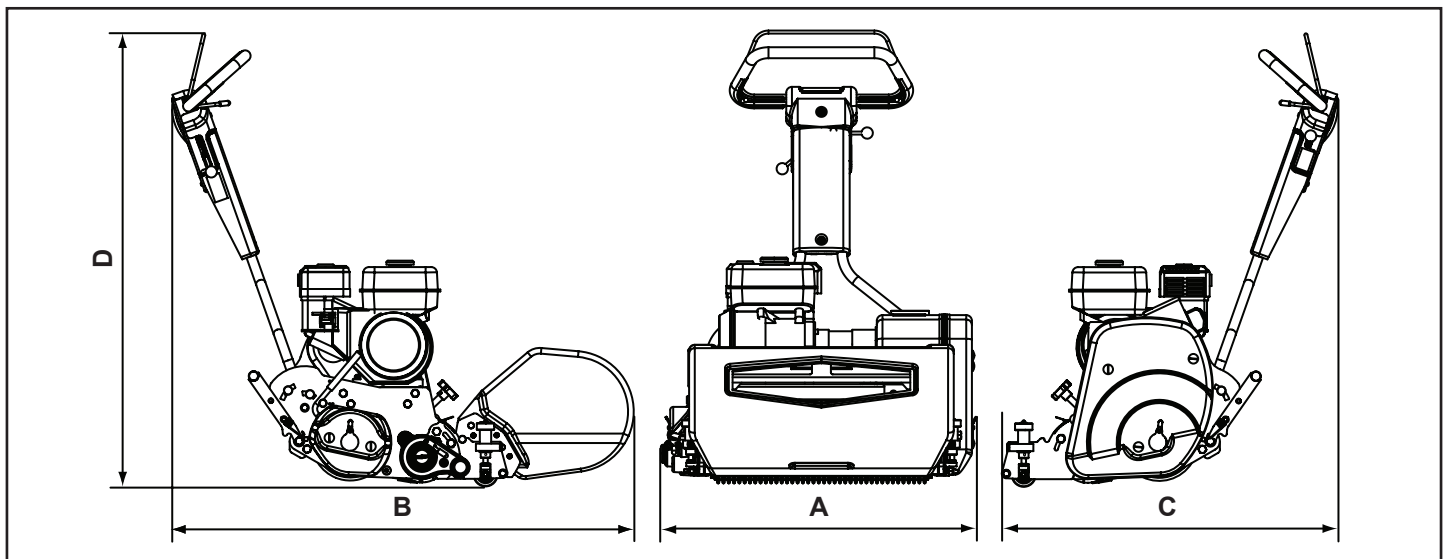

Model	Razor 560	Razor Ultra 560
A - Width (mm)	820	820
B - Length with Grassbox (mm)	1172	1220
C - Length without Grassbox (mm)	832	880
D - Height (mm)	1170	1170
Weight (Kg)	120	125
Cutting Width (mm)	560	560
Cylinder	7 Blades	11 Blades
Height of Cut (mm)	2 - 25	2 - 25
Cut Performance (11 Blade)	120 cuts/m (112 cuts/yd)	190 cuts/m (177 cuts/yd)
Engine	Honda GX120	Honda GX120
Drive System	Friction Clutch	Friction Clutch
Final Drive	Poly "V" high performance belts under constant tension	Poly "V" high performance belts under constant tension
Hand Arm Vibration (m/sec ²)	2.5	2.5
Measured Sound Power Level dB(A) LWA	91	91
Guaranteed Sound Power Level dB(A) LWA	94	94

Machine Description

Manufactured with a 22" (56cm) cutting width this mower is powered by a 4 h.p. air cooled, single cylinder, four stroke, petrol engine. The rear roller and cylinder are powered via independent friction clutches. This allows infinite speed control of the machine independent of the cylinder speed.

In the design of the machine, special attention has been given to the importance of easy service and maintenance, with the construction based on a sectional assembly system. These are: "Rear Roller", "Handle Bar", "Cylinder", "Groomer", "Front Roller" and "Drive system", all of which can be readily removed from the "Chassis unit".

The groomer attachment between front roller and cylinder is independently driven and can be disengaged as required.

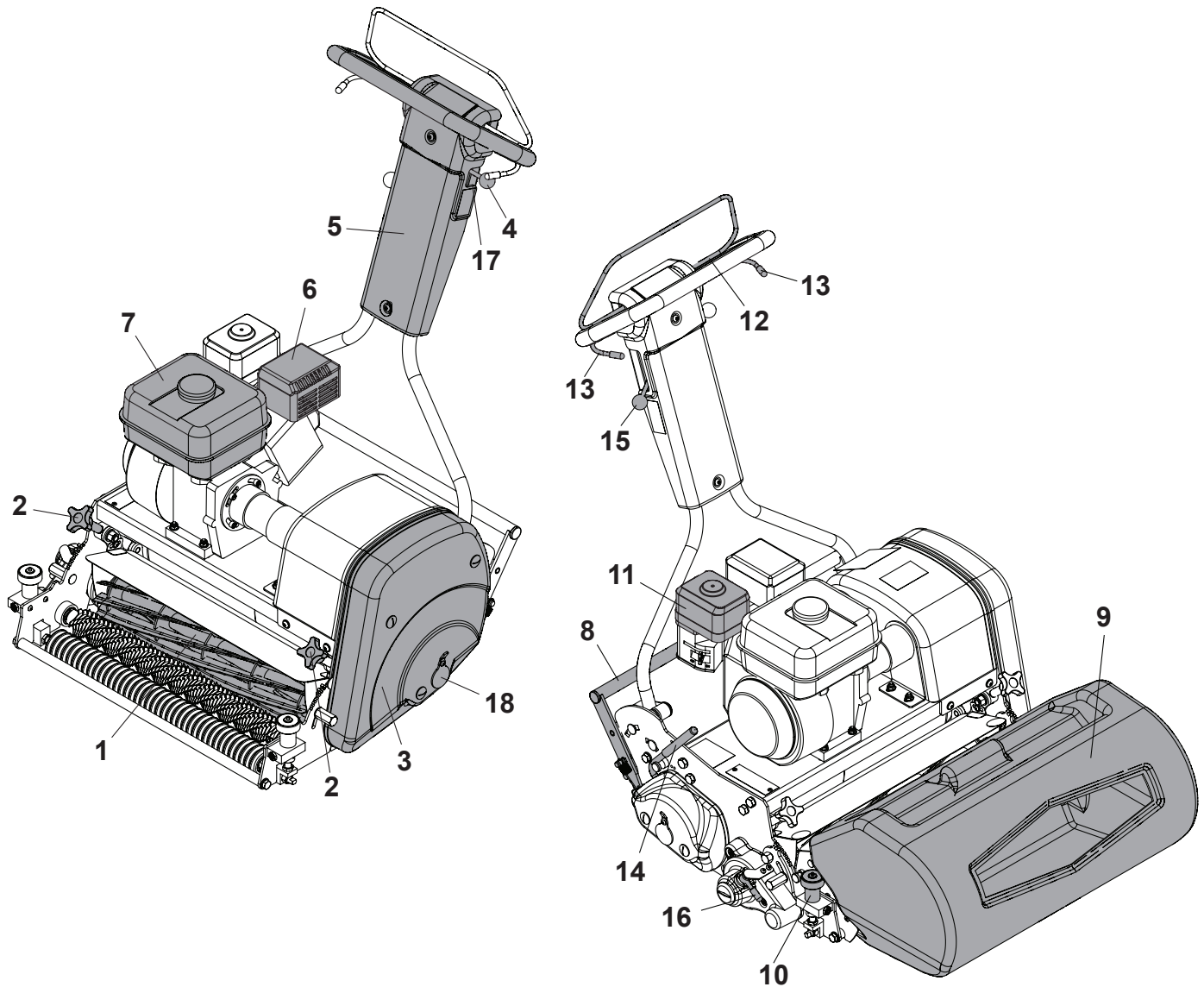

1. Cylinder
2. Bottom Blade Adjuster Knob
3. Belt Guard
4. Throttle Lever
5. Handle Bar
6. Exhaust
7. Fuel Tank
8. Wheel Kit Stand
9. Grassbox
10. Cutting Height Adjustment Knob

11. Air Filter
12. Control Hoop
13. Deadmans Handle
14. Parking Brake
15. Cylinder Control Lever
16. Groomer Control Lever
17. On / Off Switch
18. Wheel Kit Cover

Important Safety Instructions

In order to operate the machine safely please follow these Health and Safety guidelines.

TRAINING



CAUTION

*READ THE INSTRUCTIONS CONTAINED IN THIS MANUAL WITH CARE. IF YOU ARE IN ANY DOUBT PLEASE ASK YOUR EMPLOYER OR CONTACT US DIRECT AT **DENNIS**.*

- Be familiar with the controls and the proper use of the equipment.
- Never allow children or people unfamiliar with these instructions to use the mower. Local regulations or insurance may restrict the age of the operator.
- Never mow while people, especially children, or pets are nearby.
- Keep in mind that the operator or user is responsible for accidents or hazards occurring to other people or their property.

PREPARATION

- While mowing always wear substantial footwear and long trousers. Do not operate the mower barefoot or in open sandals.
- Thoroughly inspect where the equipment is to be used and remove all stones, sticks, wire, bones and other foreign objects.



WARNING *PETROL IS HIGHLY FLAMMABLE AND WILL DAMAGE GRASS IF SPILT.*

- A) Store fuel in containers specifically designed for this purpose.
 - B) Refuel out doors and do not refuel whilst smoking.
 - C) Add fuel before starting the engine. Never remove the cap of the fuel tank or add petrol while the engine is running or when the engine is hot.
 - D) If petrol is spilled do not attempt to start the engine but move the machine away from the area of spill and avoid creating any sources of ignition until the vapours have dissipated.
- Replace damaged or faulty silencers.
 - Before using the machine always inspect the safety devices including the cut off switch and the blades for excessive wear or damage. Replace if necessary.

OPERATION

- Do not operate the engine in a confined space where dangerous **CARBON MONOXIDE** fumes can collect.
- Mow only in daylight or good artificial light.
- Avoid operating the machine in wet grass where feasible.
- Always be sure of your footing on slopes.
- Walk. Never run.
- Walk across the face of slopes, never up and down.
- Exercise extreme care on slopes when changing direction.
- Do not mow excessively steep slopes.
- Use extreme caution when reversing or pulling the machine towards you.
- Stop the blades if the mower has to be tilted for transportation when crossing surfaces other than grass and when transporting the mower to and from the area to be mown.
- Never operate the mower with defective guards or shields or without the safety devices, for example without the deflector plate or grassbox in place.
- Do not change the engine governor settings or overspeed the engine.
- Disengage all blades and drive clutches before starting.
- Start the engine carefully following the instructions with feet well away from the blades.
- Do not tilt the mower when starting the engine.
- Do not put hands or feet near or under rotating parts. Keep clear of the discharge opening at all times.
- Never pick up or carry the mower while the engine is running.

FOR THE LOCATION OF CONTROLS AND COMPONENTS REF. "MACHINE DESCRIPTION" PAGE 5.

ON / OFF SWITCH (Item 17)

This switch stops the engine and can be used to do so at anytime during the operation of the machine. Ensure it is in the "ON" position before attempting to start the engine.

DEADMANS CONTROL (Item 13)

This is an operator presence control. It must be raised before the cylinder can be engaged and held in until the cylinder is disengaged. It can be held with either the left or right control, and when driving will retain itself. When taking up drive without the cylinder engaged the lever will raise automatically as the "Control Hoop" is pressed. Releasing the lever with the cylinder engaged will cause the engine to stop.

PARKING BRAKE CONTROL (Item 14)

This controls the parking brake. It is only to be engaged when the machine is stationary, it is **NOT** to stop the machine while moving. To engage, (standing behind the machine) pull the lever toward you and rotate clockwise. Push or Pull the machine slightly until the brake lever engages in the rear axle. It will be clear when this has happened as the rear roller will lockup.

To disengage, pull the lever toward you and rotate anti-clockwise. Locate the lever in the retainer on the side plate.

THROTTLE CONTROL (Item 4)

This controls the RPM of the engine and the resultant speed of the machine. Pushing the lever down will increase the RPM, pulling it back returns the engine to idle.

CONTROL HOOP [DRIVE CONTROL] (Item 12)

This controls the machines movement. Pushing the lever towards the handle will engage the friction clutch and cause the machine to drive. Releasing the hoop will return it to the original position and stop the drive. Pushing the lever will also raise the "Deadmans" controls. This is to eliminate the need to hold the "Deadmans" lever while driving the machine. Before operating the "Control Hoop" the "Parking Brake" must be **disengaged**. Failure to do this will cause the engine to stop.

CYLINDER CONTROL (Item 15)

This controls the cylinder drive. Pushing the lever down will engage the friction clutch and cause the cylinder to rotate. Before the cylinder can be engaged the "Deadmans" lever must be held in. Failing to do this will cause the engine to stop.

GROOMER CONTROL (Item 16)

This controls the groomer drive. Engagement and disengagement must only be carried out when the cylinder is stationary. To engage, (standing behind the machine) rotate the lever forwards. To disengage, return the lever to point backwards.



CAUTION

BEFORE YOU OPERATE THIS MACHINE YOU MUST READ AND STUDY THIS MANUAL. IF YOU ARE IN ANY DOUBT PLEASE ASK YOUR EMPLOYER OR CONTACT US DIRECT.

FOR THE LOCATION OF CONTROLS AND COMPONENTS REF. "MACHINE DESCRIPTION" PAGE 5.

PREPARATION FOR USE

- Ensure the turf is free from stones or other obstructions which may damage the cutting cylinder.
- Check the machine (inc. engine) is serviceable, has all guards in place and has no visible damage.
- Check the engine oil level. (Full details are given in the ENGINE Manual supplied)
- Fill the fuel tank 3/4 full with unleaded petrol.
- Set the height of cut to the required level. (See Page 10)
- Ensure the Cylinder drive is disengaged.
- Ensure the parking brake is engaged.



CAUTION

IMPORTANT INFORMATION PLEASE READ ALL THE DETAILS IN THIS SECTION AND FAMILIARIZE YOURSELF AND ALL MACHINE OPERATORS WITH THE CONTENTS.

STARTING THE ENGINE

- Switch on the fuel tap.
- Switch the handlebar cut off switch to "**ON**".
- Set the throttle control to a half open.
- Shift the choke lever to the "**Closed**" position. (Note: The choke is not required if the engine is warm or the air temperature high.)
- Grasp the recoil start handle until resistance is felt, then pull it with force.
- Do not allow the starter grip to snap back against the engine. Return it gently to prevent damage to the starter.
- Once the engine is started, gradually "**Open**" the choke lever. (Warm-up running of 3-5 minutes is recommended.)
- Set the throttle control back to the idle position.

STOPPING THE ENGINE

- Set the throttle control to the idle position.
- Switch the handlebar cut off to **OFF**.
- Close the fuel tap.

TO COMMENCE DRIVING (TRANSPORT BETWEEN SITES / NO CUTTING)

- Ensure the "**Parking Brake**" is disengaged.
- Raise the "**Deadmans**" lever (Item 13)
- Press the "**Control Hoop**" (Item 12) to the handle bar to start moving.
- Set the "**Throttle control**" to increase / reduce speed.

STOP DRIVING

- Release the "**Control Hoop**".

TO COMMENCE CUTTING

- Raise the “**Deadmans**” lever (Item 13)
- Engage the “**Cylinder Control**” Lever (Item 15)
- Press the “**Control Hoop**” (Item 12) to the handle bar to start moving.
- Set the “**Throttle Control**” to increase / reduce speed.

TO STOP CUTTING

- Disengage the “**Cylinder Control**” Lever (Item 15)
- Release “**Deadmans**” lever



NOTE

*RELEASING THE “**DEADMANS**” LEVER WITH THE CUTTER ENGAGED WILL CAUSE THE ENGINE TO STOP.*

FITTING GRASSBOX

- Disengage the cylinder drive and wait for the cutter to stop rotating.
- Hold the grass box firmly on the lip of the aperture and place the other hand in the handle on the front of the box.
- Place the two locating tabs (projecting from the grass box support plates) into the slots on the machine side plate. Lower the front of the box until the box support plate's rest on the front cross bar of the machine. Ensure both box support plates are properly located before proceeding.

FITTING TRANSPORT WHEELS

Colour code:

Right hand wheel Green

Left hand wheel Red

- Lower the stand at the back of the machine (Item 19).
- Lift the machine into position as shown.
- Rotate cover (Item 18).
- Locate the wheel assembly over the hexagon shaft. Push fully on.
- Rotate knob (Item 20) and push slightly until it locates.
- Push knob (Item 20) fully in and rotate towards the back of the machine to lock.

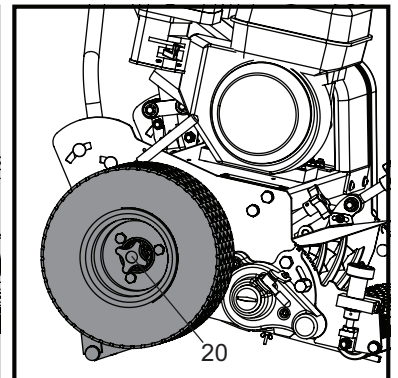
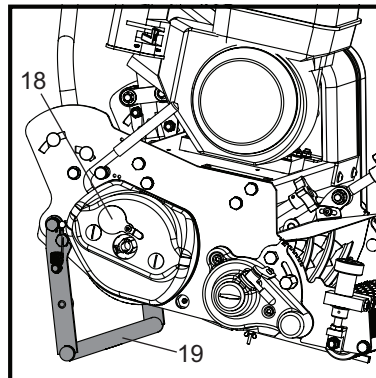

SETTING FOR HEIGHT OF CUT

Always stop the engine before adjusting the height of cut. Failure to do this may result in severe injury.

The length of grass after cutting depends on the setting of the front roller in relation to the main frame of the machine.

The 'Click' system allows easy adjustment of the front roller position, each click representing a change of 0.5mm (0.020"). The roller is set to be equal on leaving the factory so when the arrows point forward on both decals the roller is level.

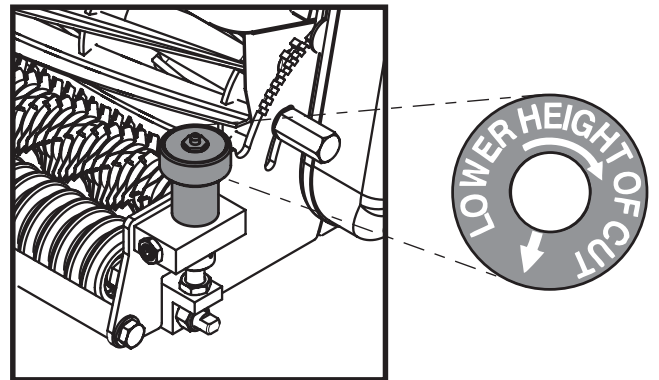

Check it is level using the setting bar between the front and rear roller with the underside of the screw leading on the bottom blade.

Either a ruler or pile of coins can be used to set the setting bar to the correct position. You are measuring the distance between the bar and the underside of the button head screw ('XX' in the Image below).

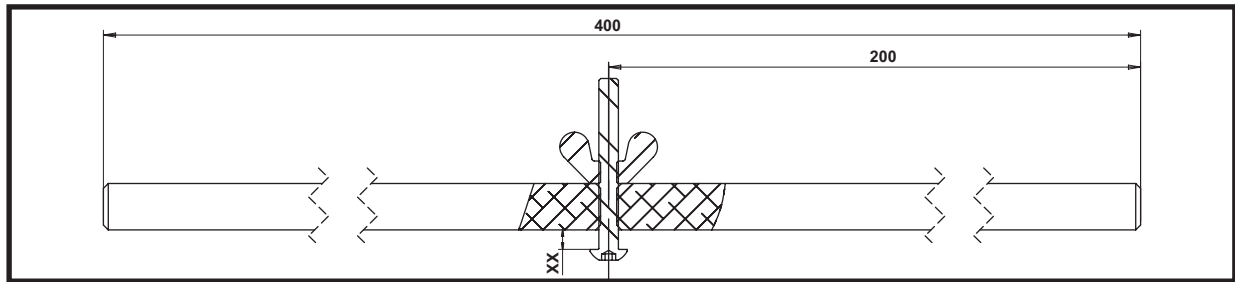

As an indication coins measure the following:-

- | | | |
|-----------------------|-----------------------|-------------------------|
| - 1p 1.58mm (0.063") | - 2p 1.80mm (0.071") | - 5p 1.73mm (0.067") |
| - 10p 1.84mm (0.072") | - 50p 1.84mm (0.072") | - £1.00 3.14mm (0.124") |

Remember height of cut is effected by moisture of turf , weight of machine and the thatch density. Different makes of machine cut at different heights when set to the same position with the setting bar. We suggest you set it to a couple of mm above your planned height and then come down in height by trial.

If on setting the height of operation you find it needs altering once on the green simply click the adjusters up or down the same on each side until the desired height of operation is achieved.

Always check height of cut/operation with the setting bar provided. Check in two positions i.e. one at either end of the cassette. Failure to do this could result in an uneven cut.

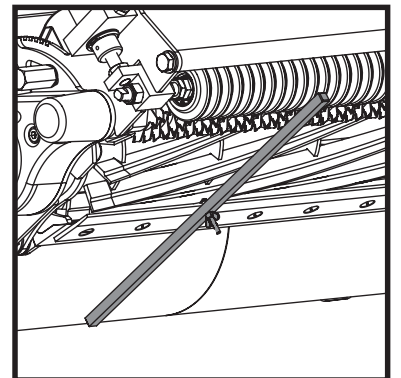

GROOMER (RAZOR ULTRA ONLY)

The groomer unit has been designed to be removed easily from the “**Chassis**” for maintenance purposes. It is driven from the cylinder by a robust timing belt.

The groomer is **NOT** a deep scarifier. Failure to use correct will invalidate the warranty and could cause damage to the drive system.

The tungsten tipped blades are designed for cutting and teasing up horizontal growths on fine turf prior to cutting with the cylinder. Its operating height should always be above or level with the setting bar that is 0 to +5mm depending on conditions. Regular use of the groomer will promote healthy sward and keep thatch growth under control.

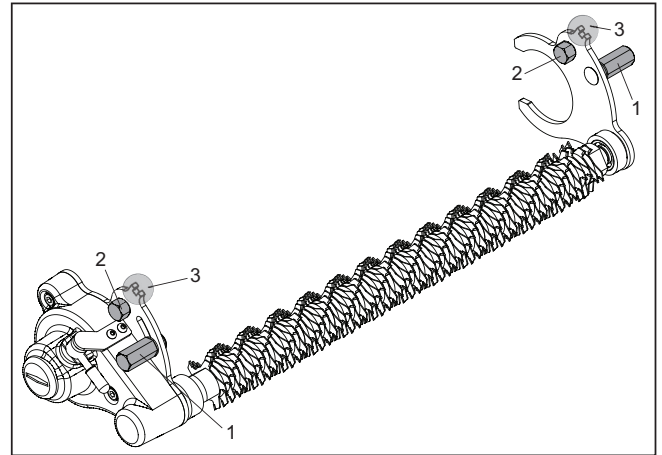

To set:

- Slacken 2-off lock nuts (Item 1) ¼” turn [19mm spanner]
- Rotate the groomer equally both sides (Item 2) [19mm spanner]
- Align the grooves (Item 3) on the arm with the grooves on the machine side plates at the desired height.
- When set, tighten the lock nuts (Item 1).
- If the groomer reel is not required set it up out of the way at approximately 10mm above the operating height of cut.
- Beware of transporting machine with groomer in low position so as to avoid damage to tungsten tipped blades.

SETTING THE CYLINDER

The cylinder unit has been designed to be removed easily from the “**Chassis**”, for grinding and maintenance. The shear blade carrier pivots to bring the blade into a cut position with the cylinder. The cylinder to bottom blade is to be set when mounted in the “**Chassis**”.

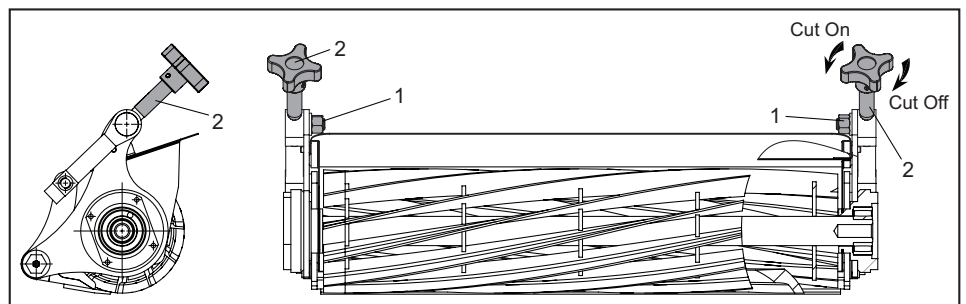

To set:

- Slacken 2-off lock nuts (Item 1) ¼” turn [19mm spanner]
- Rotate the knobs (Item 2) anti-clockwise to bring the blade towards the cylinder.
- Check the setting using thin paper along the length of the cylinder.
- Adjust until it cuts along the whole length.
- When set, tighten the lock nuts (Item 1).
- Recheck Adjustment.
- Do **NOT** set the cylinder hard to the bottom blade. This will cause excessive wear of both components and increase fuel consumption.

HANDLE BAR ADJUSTMENT

The “**Handle bars**” are adjustable to achieve the correct working height for the operator.

To set:

- Slacken 4-off nuts (Item 1) $\frac{1}{4}$ ” turn [17mm spanner]
- Raise / lower the “Handle Bar” to the desired position”
- When set, tighten the nuts (Item 1).

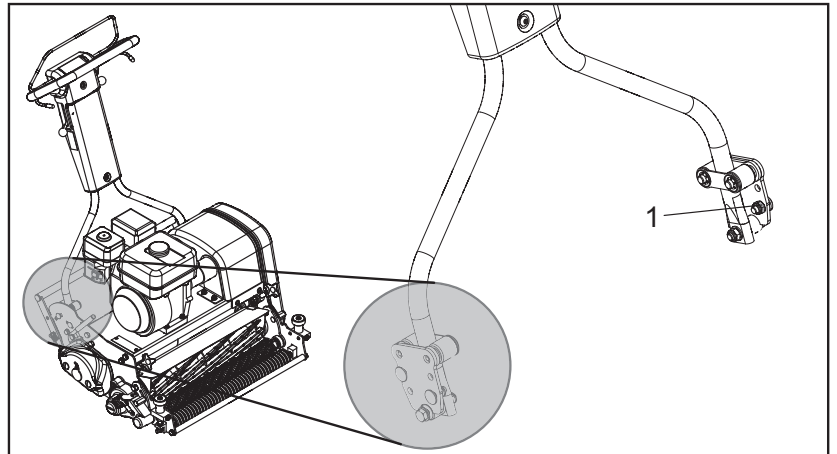

ENGINE

The machine is fitted with a Honda GX120 petrol engine.

For full specifications please refer to the manufacturers instruction manual included.

Area	Maintenance	First 4 Hours	First Month / 20 Hours	3 Months / 50 Hours	6 Months / 100 Hours
Engine Oil	Check Level	✓			
Engine Oil	Change		✓		✓
Air Filter	Check Condition / Clean		✓		✓
Spark Plug	Change				✓

OIL / FUEL TYPE & QUANTITY - SPARK PLUG TYPE

Engine Model	Oil Type	Quantity (Ltr)	Fuel Type	Capacity (Ltr)	Spark Plug Type	Electrode Gap (mm)
Honda GX120 Petrol	SAE 10W-40	0.6	Unleaded	2.5	BM6ES or BPR6ES	0.7 - 0.8

DRIVING BELTS

The main drive to both rear roller and cassette is via hard wearing TBA poly-V type belts which provide for smooth trouble free operation. To ensure the best performance the following instructions should be carefully followed.

Belt tension is the single most important factor necessary for long, satisfactory service life of any belt drive.

Under-tensioning leads to belt slip causing rapid wear; over tensioning means excessive strain on belt and bearings. Between these two extreme conditions is a reasonable range of tension within which the belt will operate. Belt tension can be assessed by the 'deflection' method.

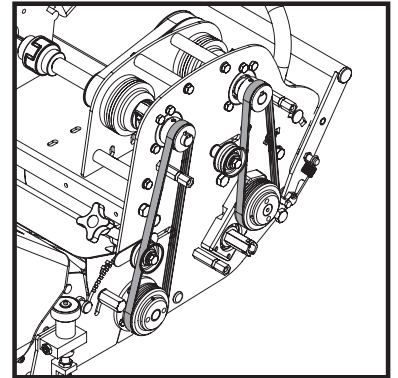

NOTE

CORRECTION CAN BE MADE BY ADJUSTMENT OF THE BELT TENSIONERS. REMOVE THE DRIVING BELT COVER. THE BELT TENSIONERS ARE RETAINED IN A SLOTTED HOLE ALLOWING ADJUSTMENT TO BE MADE ONCE THE HOLDING HEXAGON HEADED BOLTS HAVE BEEN LOOSENED. WHEN ADJUSTED CORRECTLY THE TENSIONERS SHOULD STILL ROTATE EASILY WITH FINGER PRESSURE. ENSURE THE TENSIONER BOLTS ARE SECURE BEFORE REPLACING THE COVER.

"Belts will be sufficiently tensioned if the deflection force applied at mid span to produce a deflection equal to 16mm per meter of span distance falls between 5 and 9 Newtons per Rib" (TBA Belting).

In practical terms this relates to about 5mm of deflection under moderate finger pressure on the non tensioner side.

If fitting new belts it is advisable to observe the drive for the first 20-30 minutes. It may be necessary to make an adjustment to compensate for the normal drop in tension during the run-in period.

CLUTCH CABLE ADJUSTMENT

Over time the cables that operate the friction clutches for the “**Cylinder**” and “**Rear Roller**” will need adjusting. This adjustment can be done at the “**Handle Bar**” or at the “**Chassis**”.

To set at “**Handle Bar**”

- Remove handle bar cover [4mm Allen key]
- Slacken 2-off lock nuts on relevant cable [10mm and 7/16” spanner]
- Adjust cable to desired tension. Note: Neither “**Cylinder**” or “**Rear Roller**” should operate with controls in **OFF** position.
- When set, tighten the lock nuts.

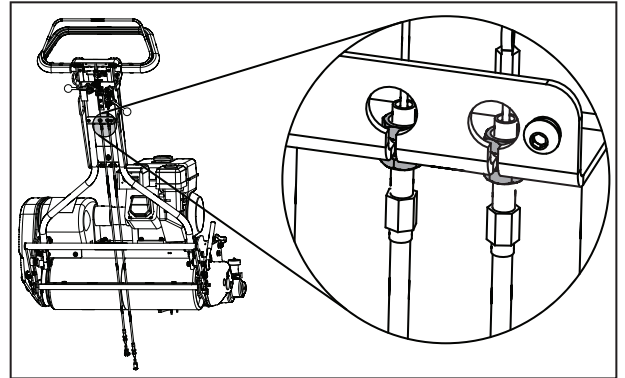

To set at “**Chassis**”

- Remove clutch cover [13mm spanner]
- Slacken 2-off lock nuts on relevant cable [2-off 13mm spanners]
- Adjust cable to desired tension. Note: Neither “**Cylinder**” or “**Rear Roller**” should operate with controls in OFF position.
- When set, tighten the lock nuts.

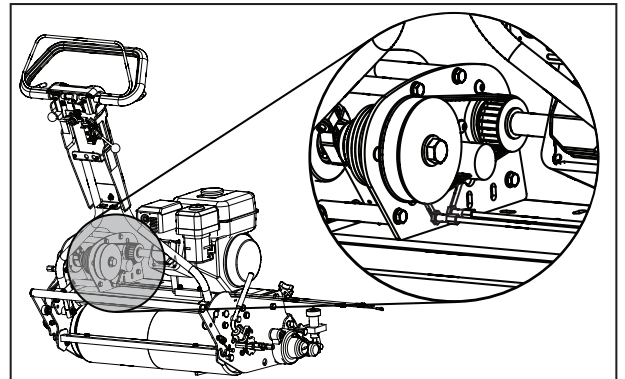

NOTE

ENSURE THE LOCK NUTS ARE TIGHT AND SECURE AND CHECK OPERATION IS SATISFACTORY BEFORE REPLACING THE CLUTCH COVER AND SCREWS.

Storage

The machine should always be kept in a clean dry place, free from condensation. After use ensure that the machine is thoroughly clean, dry and free from grass and mud. Before off season storage smear a thin layer of grease on to the cutter blades and the shear blade.

Under no circumstances must the machine be steam cleaned as this may remove grease from the pre packed bearings.

Because of the nature of lead free petrol we recomend that if the machine is being left unused for more than 2 weeks the carburetor is run dry. Allow the engine to run out of fuel with the fuel tap switched off.

REAR ROLLER

(6-months)

The main drive roller is split into three sections incorporating a differential gear system running in an oil bath. The old oil should be drained off and the bath replenished with 1 pint (550ml) of clean oil.

(1-month)

A grease point is located under the belt guard on the side plate of the machine. This is to lubricate the internal spur gear that provides drive to the rear roller. Apply one pump of grease. Do not over grease.

CONTROL LEVERS AND CABLES

(2-months)

Apply a small amount of oil to the control cables. Flow down the protective cables can be assisted by operating the lever a few times after lubricating.

FRONT ROLLER ADJUSTERS

(2-months)

Apply a small quantity of copper grease or similar to the adjuster studs to prevent corrosion and ease adjustment.

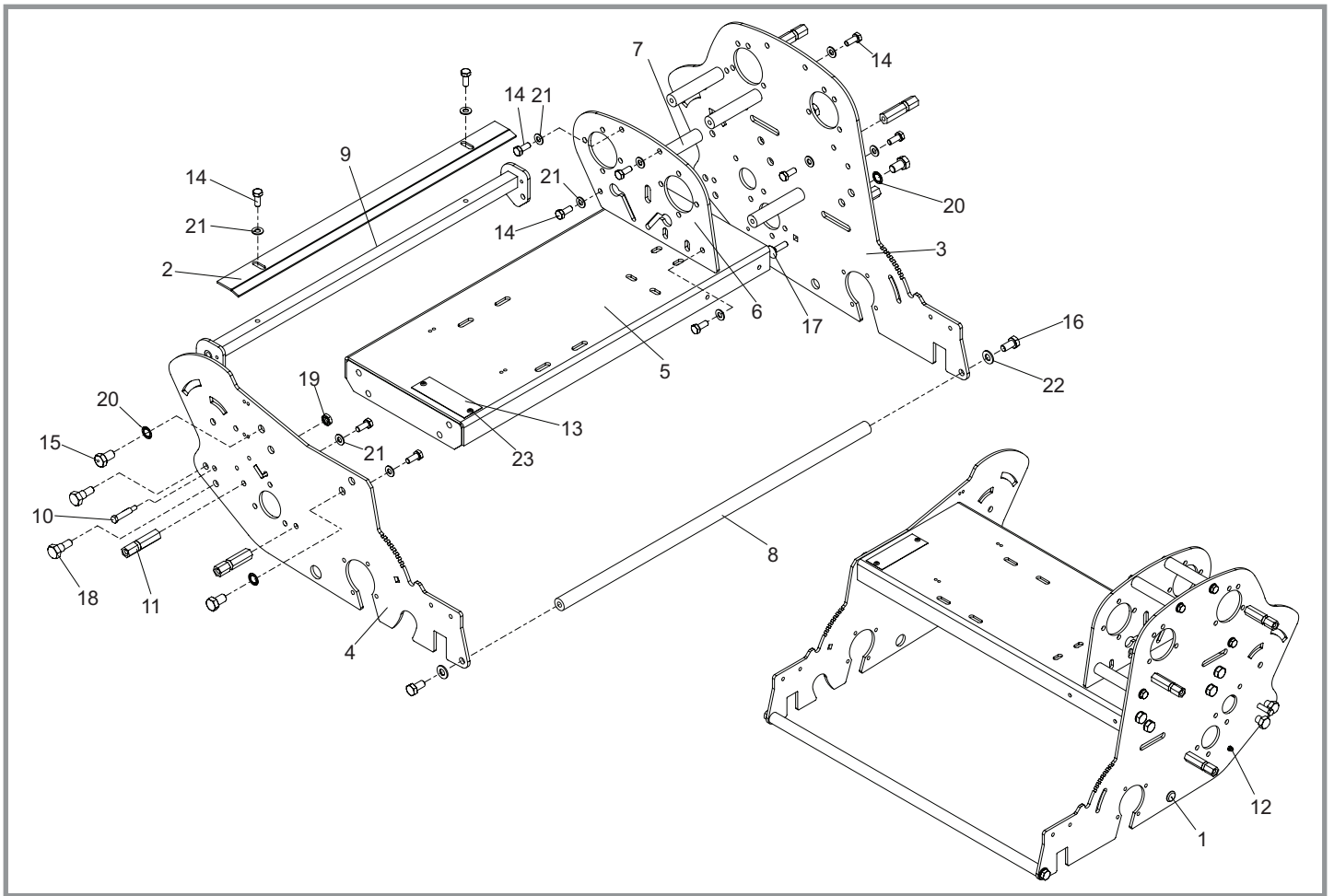

1.01

Chassis

Item No.	Part No.	Description	Quantity
1	228062	3/4" Tube Bung (3132)	1
2	229342	Scraper Bar 22"	1
3	240001	Side Plate L.H. (Ultra)	1
3	240220	Side Plate L.H. (Std)	1
4	240002	Side Plate R.H. (Ultra)	1
4	240221	Side Plate R.H. (Std)	1
5	240003	Engine Deck Assy 22"	1
6	240006	Clutch Support Plate	1
7	240024	Clutch Spacer	4
8	240039	Tie Bar Front 22"	1
9	240080	Tie Bar W.A. 22"	1
10	240166	Stand Spring Retainer	2
11	240188	Belt Guard Stud	5
12	J20064	Grease Nipple 1/4" UNF	1
13	J20297	Serial Number Plate	1
14	SP01009	Hex Set Screw M8 x 20	14
15	SP01021	Hex Set Screw M12 x 20	8
16	SP01034	Hex Set Screw M10 x 20	2
17	SP01038	Coach Bolt M8 x 30	1
18	SP01042	Shoulder Bolt 12 x 10 M10	4
19	SP02013	Nut M10 Lock (Thin)	2
20	SP03006	Washer M12 Toothed	8
21	SP03008	Washer M8 Form A	14
22	SP03011	Washer M10 Form A	2
23	SP05001	Rivet 4.8 x 10	2

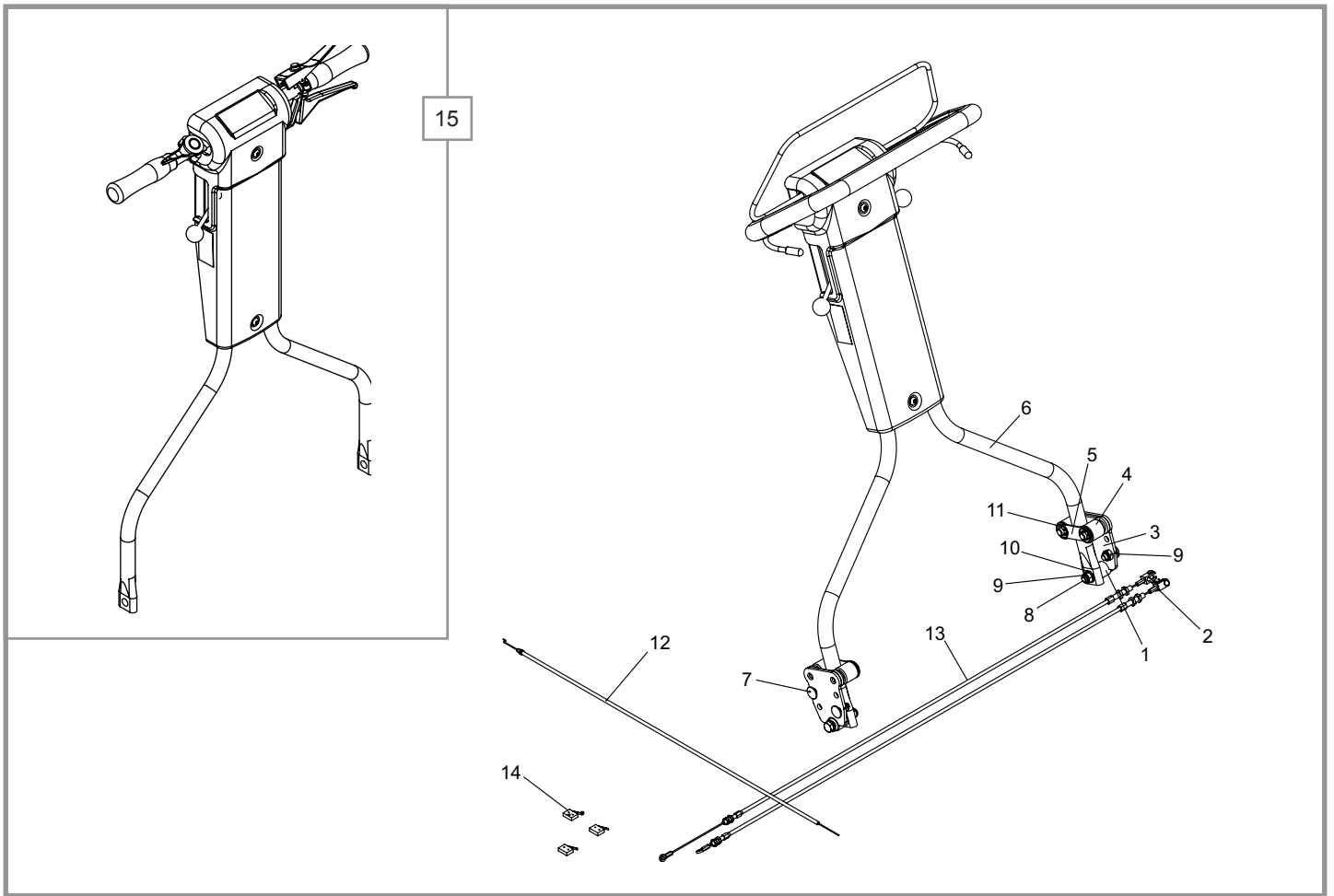

2.01

'T' & 'D' Handle

Item No.	Part No.	Description	Quantity
1	229166	Handle Pivot Bush	2
2	229378	Cutter Drive Clutch Cable	1
3	230200	Handle Bracket W.A.	2
4	230203	Handle Buffer	4
5	230205	Handle Bracket Support	2
6	800202	'D' Handle Assy*	1
7	SP01044	Coach Bolt M10 x 25	4
8	SP01047	Hex Set Screw M10 x 60	2
9	SP02008	Nut M10 Nyloc	6
10	SP03011	Washer M10 Form A	4
11	SP07001	Starlock 12mm	4
12	SP12002	Throttle Cable G860 / G760 ('D' Handle Only)	1
12	J20112	Throttle Cable (Razor 'T' Only)	1
13	SP12003	Cable Drive Clutch ('D' Handle Only)	1
13	229723	Cable Drive Clutch (Razor 'T' Only)	1
14	SP12005	"Micro Switch Harness (Razor)" ('D' Handle Only)	1
14	SP12011	"Switch Harness (Razor)" ('T' Handle Only)	1
15	800223	'T' Handle Assembly**	1

NOTE

* For 'D' Handle Assembly breakdown, see Section 2.02

** For 'T' Handle Assembly breakdown, see Section 2.03

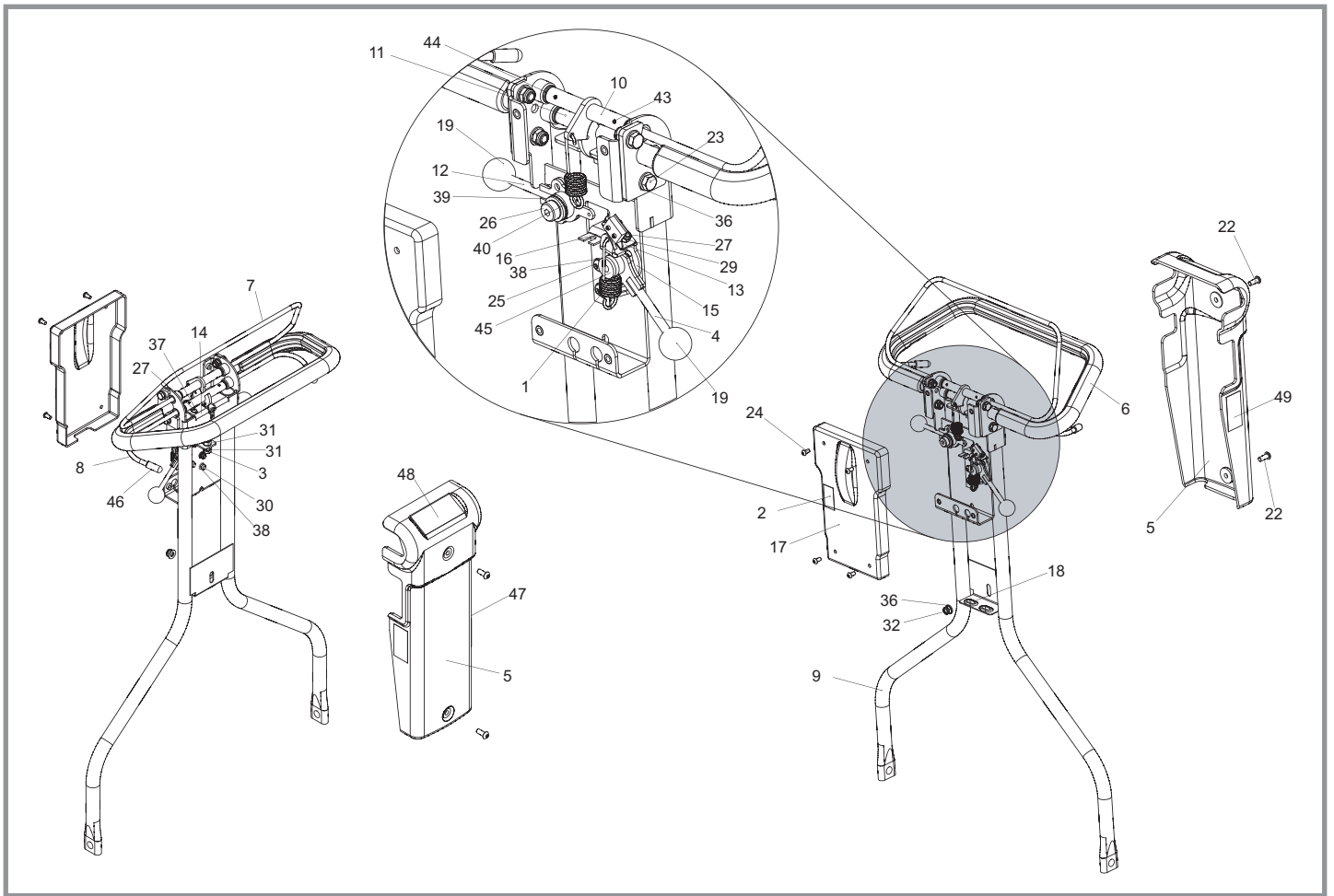

2.02

'D' Handle - Main Assembly

Item No.	Part No.	Description	Quantity	Item No.	Part No.	Description	Quantity
1	229167	Clutch Spring	3	38	SP03010	Washer M6 Form A	6
2	229599	Engine On / Off Decal	1	39	SP03012	Washer M12 Form A	1
3	229620	Bolt For Spring	1	40	SP03019	Washer M12 Wave	1
4	230170	Lever R.H. W.A.	1	41	SP03020	Shim 12 x 18 x 1	3
5	240027	Guard Handle	1	42	SP03027	Washer M2	4
6	240060	Handle Hoop Assy	1	43	SP05007	Pin Slotted M3 x 16	4
7	240065	Control Hoop	1	44	SP06007	Bush Oilite Al0812 - 12	4
8	240066	Control Safety Bar	2	45	SP06009	Bush Lever Pivot	1
9	240071	Handle W.A.	1	46	SP14003	Sleeve Plastic 8mm x 28	2
10	240079	Throttle Link W.A.	1	47	SP18001	Decal Throttle (Razor)	1
11	240084	Safety Bar Link W.A.	1	48	SP18002	Decal Drive (Razor)	1
12	240140	Throttle Lever W.A. Support	1	49	SP18003	Decal Cutter (Razor)	1
13	240169	Sensor Angle Plate	1				
14	240170	Sensor Plate	1				
15	240171	Cutter Control Plate	1				
16	240172	Throttle Control Plate	1				
17	240173	Control Cover	1				
18	260138	Grommet PV270A	2				
19	J20017	Knob - Red	2				
22	SP01006	Button Head M8 x 20	2				
23	SP01009	Hex Set Screw M8 x 20	5				
24	SP01016	Button Head M6 x 12	4				
25	SP01019	Button Head M6 x 16	5				
26	SP01029	Shoulder Bolt 12 x 25 M10	1				
27	SP01069	Button Head M5 x 12	4				
28	SP01070	Cap Head M2 x 12	4				
29	SP02002	Nut M5 Nyloc	4				
30	SP02004	Nut M6 Nyloc	4				
31	SP02005	Nut M8 Std	2				
32	SP02006	Nut M8 Nyloc	6				
33	SP02008	Nut M10 Nyloc	1				
34	SP02011	Nut M6 Lock (Thin)	1				
35	SP02032	Nut M2 STD	4				
36	SP03008	Washer M8 Form A	11				
37	SP03009	Washer M5 Form A	4				

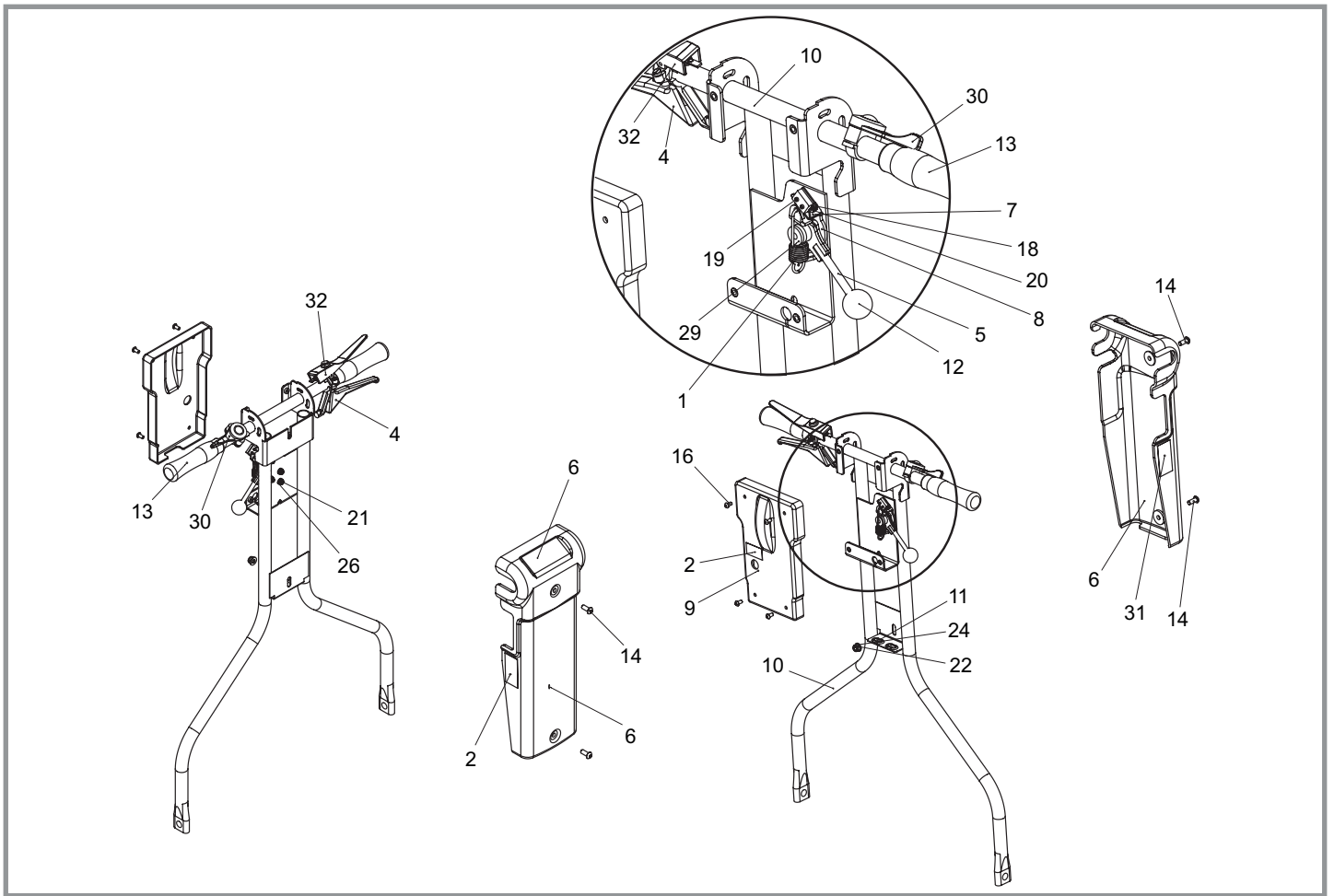

2.03

'T' Handle - Main Assembly

Item No.	Part No.	Description	Quantity
1	229167	Clutch Spring	1
2	229599	Engine On / Off Decal	1
3	229723	Roller Drive Cable G610	1
4	229754	Clutch Lever Lever	1
5	230170	Lever R.H. W.A.	1
6	240027A	Guard Handle (Tee Bar)	1
7	240169	Sensor Angle Plate	1
8	240171	Cutter Control Plate	1
9	240173	Control Cover	1
10	240240	Handle Bar W.A. (T Bar)	1
11	260138	Grommet PV270A	2
12	J20017	Knob - Red	1
13	J20107	Handle Grip Rubber	2
14	SP01006	Button Head M8 x 20	2
15	SP01009	Hex Set Screw M8 x 20	1
16	SP01016	Button Head M6 x 12	4
17	SP01019	Button Head M6 x 16	2
18	SP01069	Button Head M5 x 12	2
19	SP01070	Cap Head M2 x 12	2
20	SP02002	Nut M5 Nyloc (T)	2
21	SP02004	Nut M6 Nyloc	4
22	SP02006	Nut M8 Nyloc (T)	2
23	SP02032	Nut M2 Std	2
24	SP03008	Washer M8 Form A	3
25	SP03009	Washer M5 Form A	2
26	SP03010	Washer M6 Form A	4
27	SP03020	Shim 12 x 18 x 1	1
28	SP03027	Washer M2	2
29	SP06009	Bush Lever Pivot	1
30	SP12012	Throttle Control	1
31	SP18003	Decal Cutter (Razor)	1
32	SP12010	Deadman Lever	1

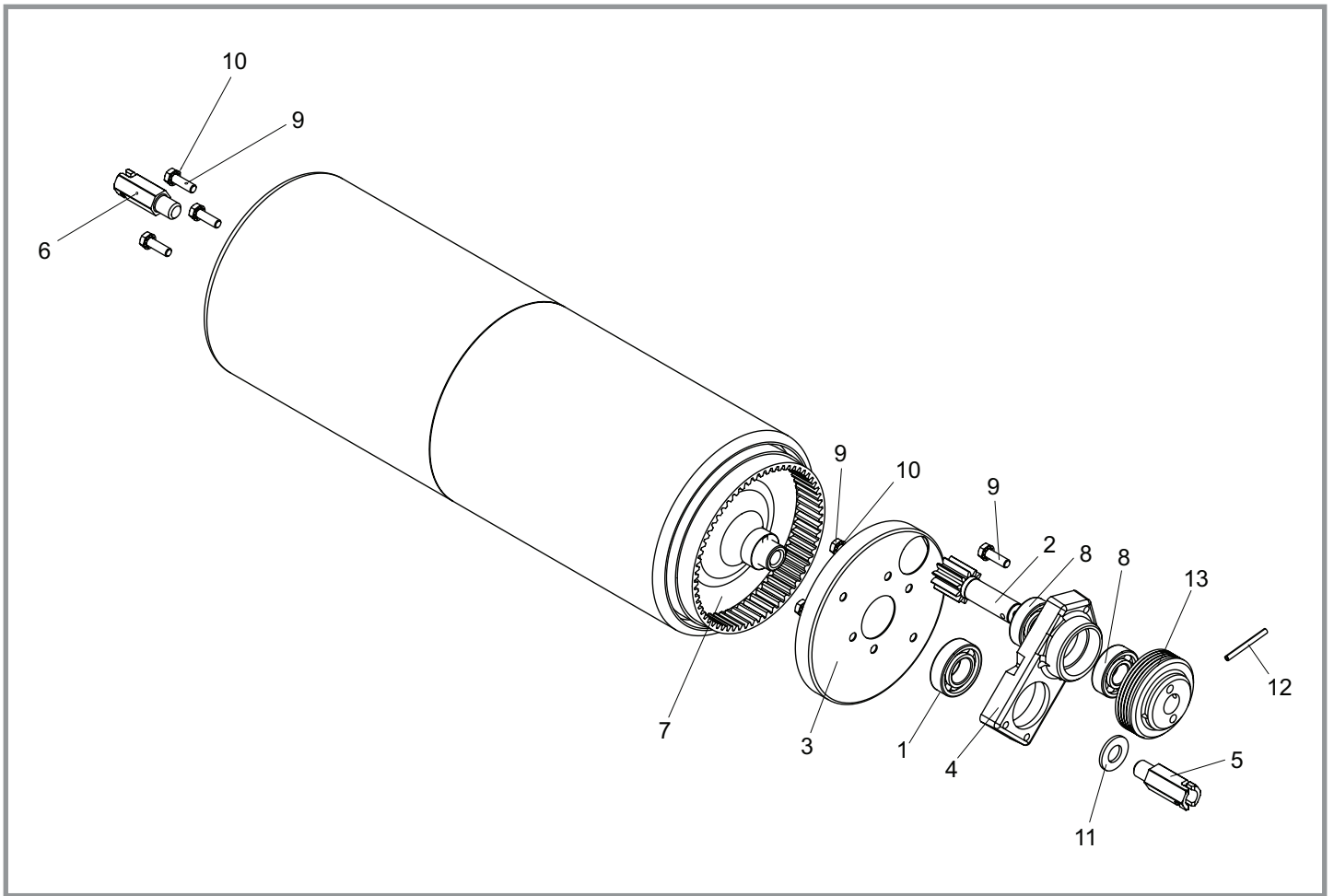

3.01

Rear Roller - Main Assembly

Item No.	Part Number	Description	Quantity
1	062662	Bearing 6205-2RS 3	1
2	229011	Pinion Shaft 11T	1
3	229031	Dirt Excluder	1
4	229033	Roller Bearing Housing Oblong	1
5	240151	Shaft Extension L.H.	1
6	240152	Shaft Extension R.H.	1
7	800198	Rear Roller Assy 22"	1
8	J20052	Bearing 6204-2RS 3	2
9	SP01045	Hex Set Screw M8 x 25	8
10	SP03004	Washer M8 Toothed	8
11	SP03021	Washer M16 Form C	1
12	SP05008	Pin Spirol M5 x 50	1
13	SP11015	Drive Pulley Land Roll	1

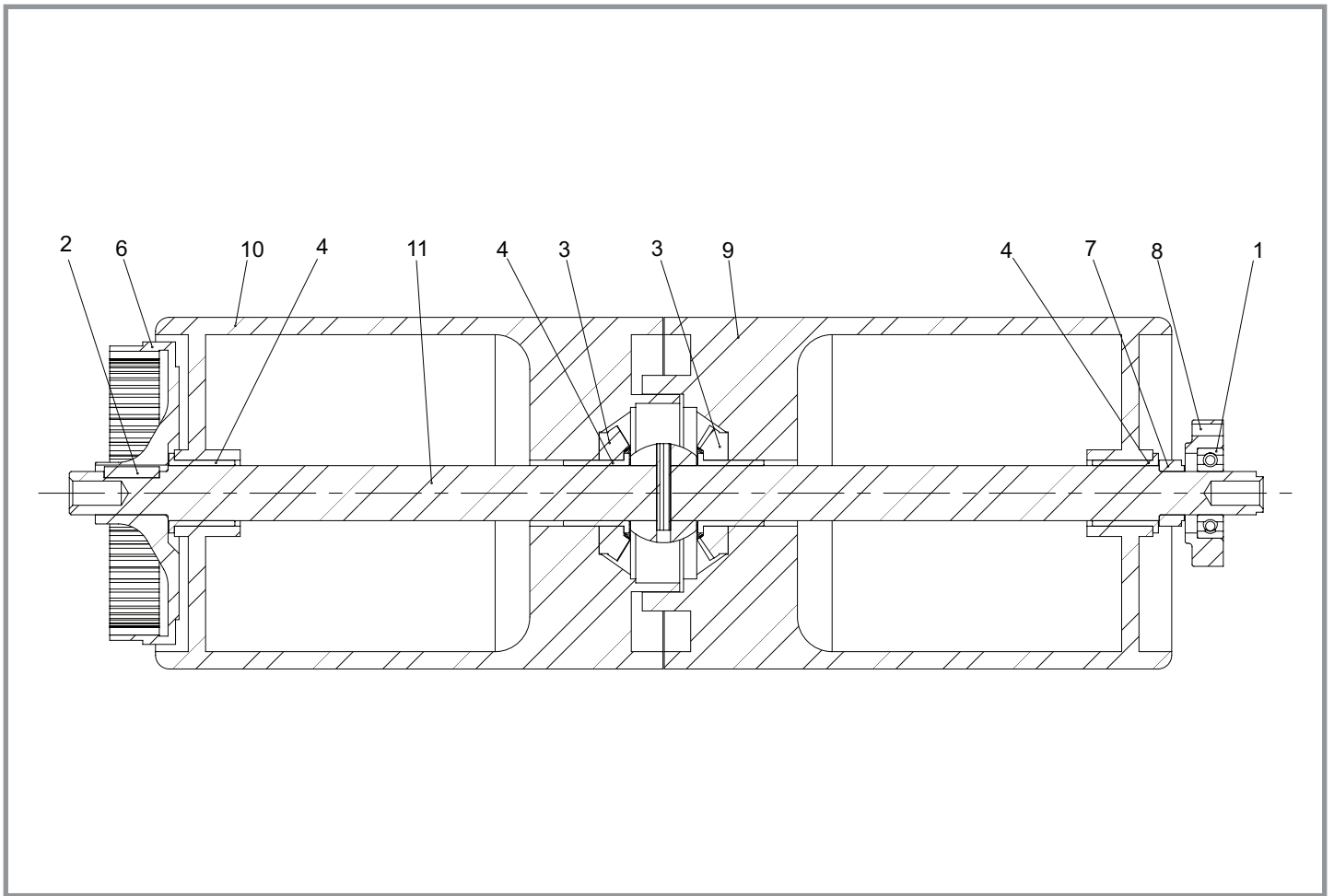

3.02

Rear Roller - Roller Assembly

Item No.	Part No.	Description	Quantity
1	062662	Bearing 6205-2RS 3	1
2	228049	Key 1/4" x 1/4" x 1 1/4" Rd End	1
3	229022	30 Tooth Bevel Gear	2
4	229023	Bush Oilite MBC AJ2024 x 1.5	4
5	229025	20 Tooth Bevel Gear	2
6	229030	Internal Gear	1
7	229032	Roller Locking Collar	1
8	229104	Landroll Bearing Housing	1
9	229363	RH Rear Smooth Roller (Sport)	1
10	229364	LH Rear Smooth Roller (Sport)	1
11	800212	Rear Roller Shaft Assy 22"	1

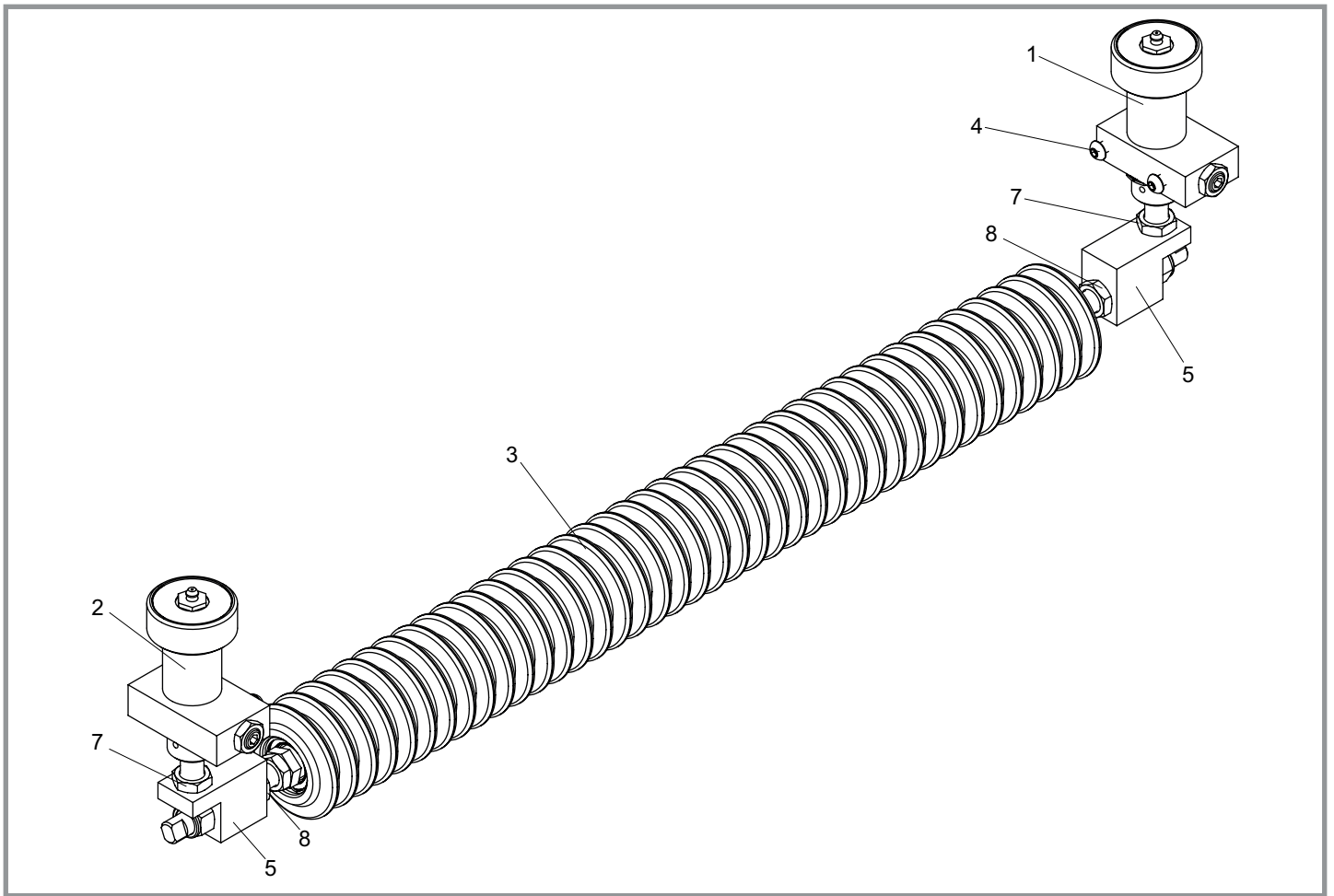

4.01

Front Roller - Main Assembly

Item No.	Part No.	Description	Quantity
1	800148	Click Height Adjuster L.H.*	1
2	800149	Click Height Adjuster R.H.*	1
3	800214	Weile Roller Assy 22" (Razor)**	1
4	SP01019	Button Head M6 x 16	4
5	240105	Roller End Block Assembly	2
7	SP02010	Nut M12 Nyloc	2
8	SP02014	Nut M12 Lock (Thin)	2

NOTE

* For Click Height Adjusters breakdown, see Section 4.02

** For Weile Roller Assembly breakdown, see section 4.03

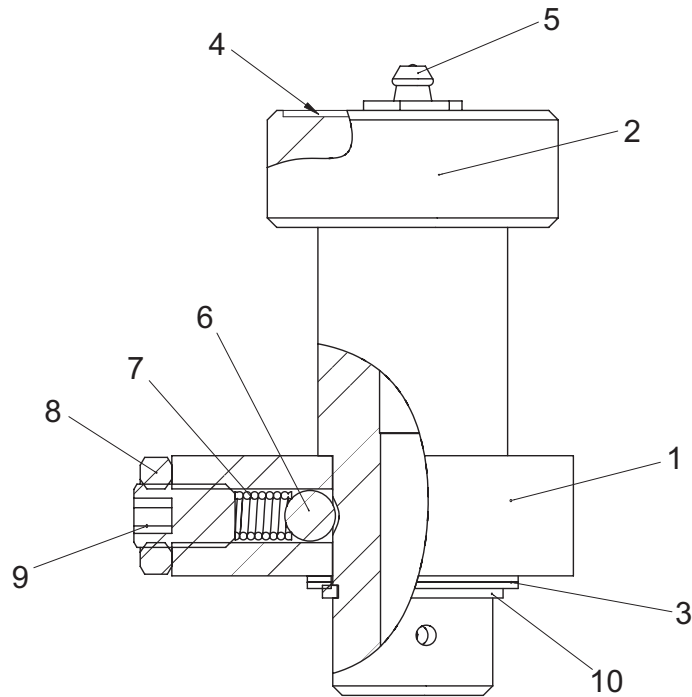

4.02

Front Roller - Click Height Adjusters

Item No.	Part No.	Description	Quantity
1	J20517	Ht. Adjuster Block	1
2	J20518	Height Adjuster Knob	1
3	228092	Shim Id 25.8 x 1 Thk	2
4	J20519	Decal Height Of Cut	1
5	J20528	Grease Nipple 1/4" Bsp	1
6	J20525	Steel Ball 8mm	1
7	J20526	Spring	1
8	SP02013	Nut M10 Lock (Thin)	1
9	SP01018	Grub Screw M10 x 16	1
10	J20527	Circlip D1460 - 25	1

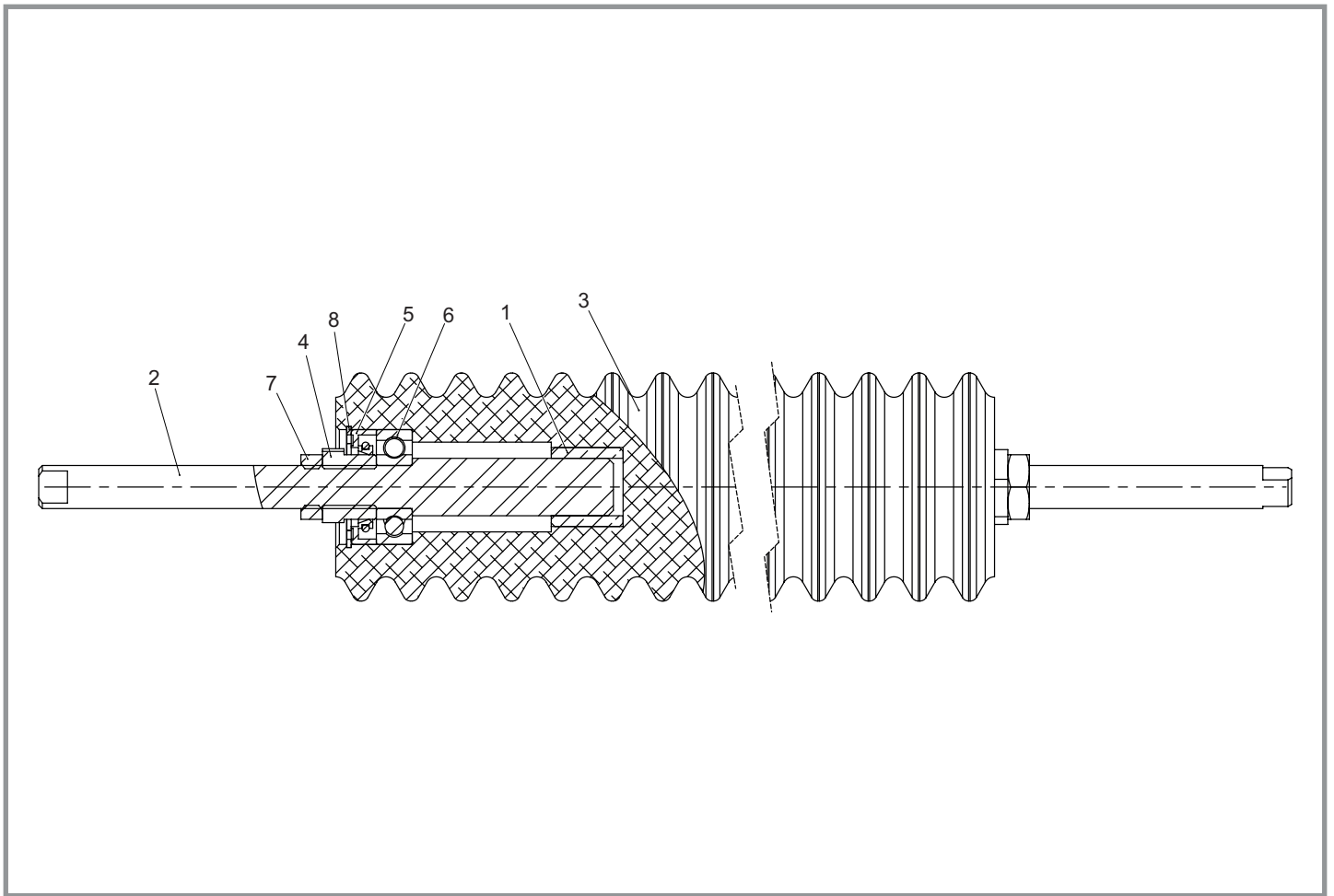

4.03

Weile Roller Assembly

Item No.	Part No.	Description	Quantity
1	229833	Bush Oilite AL1622 - 20	2
2	230262	Weile Roller Stub Shaft	2
3	240108	Weile Roller Body 22" Razor	1
4	J209068	Nut Locking	2
5	J209071	Seal Single Lip	2
6	J209105	Bearing 6201-2RS	2
7	SP02014	Nut M12 Lock (Thin)	2
8	SP07003	Circlip D1300 0320	2

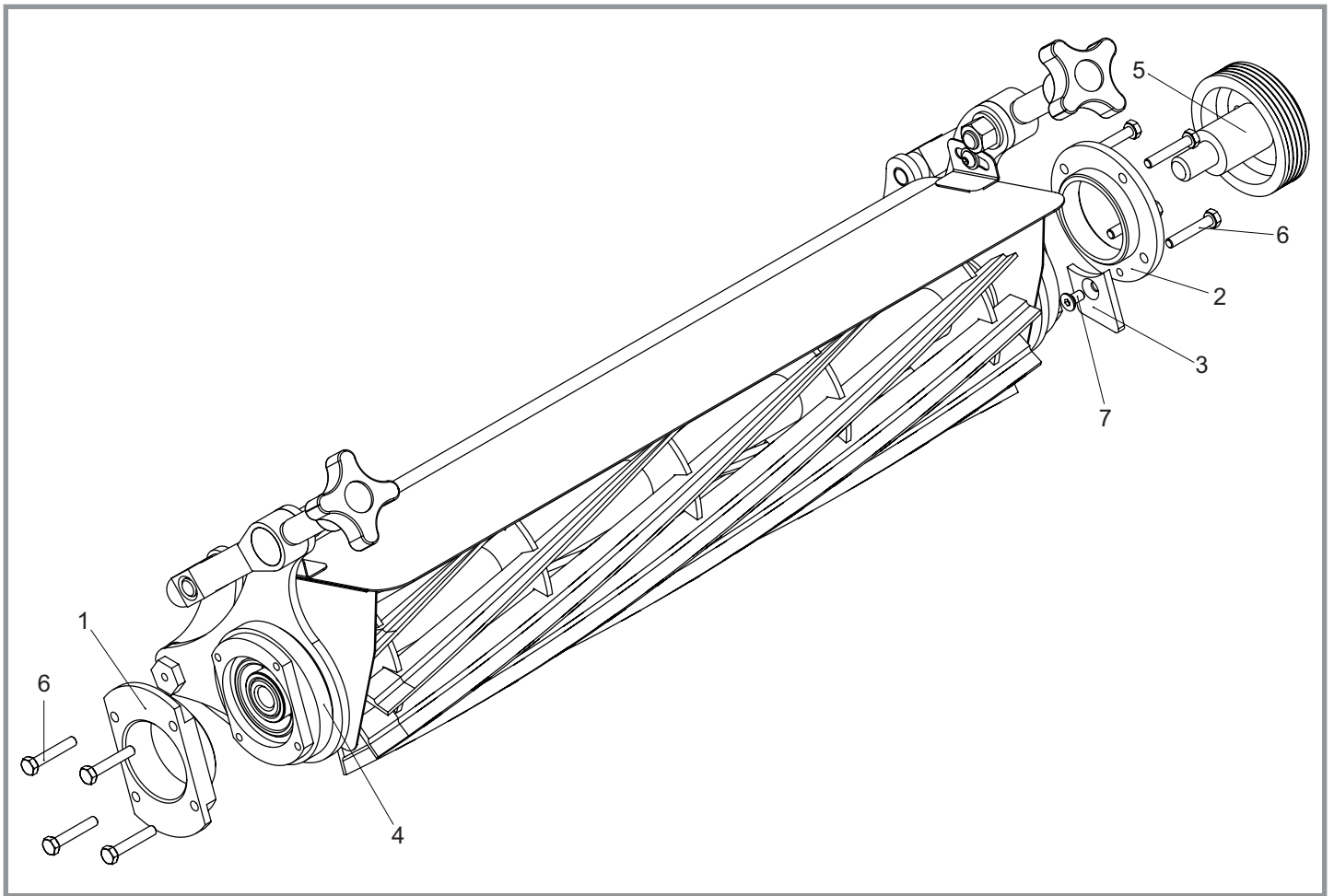

5.01

Cylinder - Main Assembly

Item No.	Part No.	Description	Quantity
1	240034	Cylinder Alignment Collar R.H. (Ultra)	1
1	240225	Cylinder Alignment Collar R.H. (Std)	1
2	240037	Cylinder Alignment Collar L.H.	1
3	240086	Slot Cover	1
4	800196	Cylinder Assy 22" (Ultra)*	1
4	800215	Cylinder Assy 22" (Std)*	1
5	800213	Pulley Assy Cylinder	1
6	SP01054	Hex Set Screw M6 x 35	8
7	SP01067	Csk Cap Head M6 x 12	1

NOT SHOWN

-	J20430	Caphead M6 x 30 (Use with 240225)	4	} STD Only
-	229892	Bolt M16 LH (Screw into Cylinder RH)	1	
-	SP03021	Washer M16 Form C (Screw into Cylinder RH)	1	

NOTE

*For Cylinder Assembly breakdown, see section 5.02

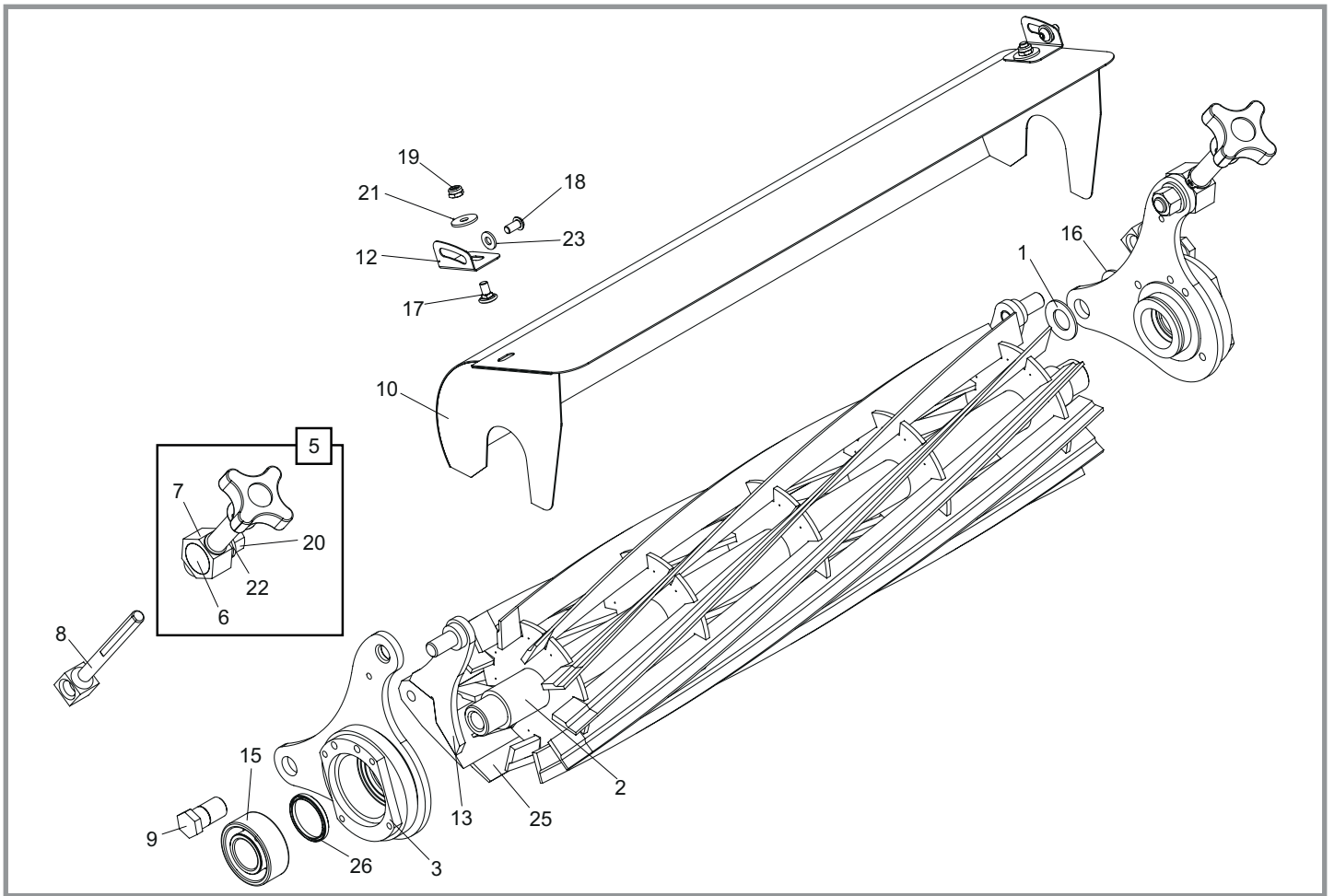

5.02

Cylinder - Cylinder Assembly

Item No.	Part No.	Description	Quantity
1	228074	D315163175 Belleville Washer	1
2	240030	Cylinder 22" 11 Blade (135 X 559)	1
2	240230	Cylinder 22" 7 Blade (135 X 559)	1
3	240040	Bearing Housing Cylinder R.H.	1
4	240041	Bearing Housing Cylinder L.H.	1
5	800224	Shear Blade Adjuster Assy	2
6	240045	Shear Blade Adjuster Pin	2
7	240046	Shear Blade Adjuster Block	2
8	240048	Shear Blade Adjuster Bar	2
9	240049	Shear Blade Bolt (2011 >)	2
9	240077	Shear Blade Bolt (> 2011)	2
10	240055	Deflector W.A.	1
11	240059	Deflector Bracket L.H.	1
12	240070	Deflector Bracket R.H.	1
13	800197	Shear Blade Carrier Assy 22"	1
15	J20255	Bearing 5205 - 3205 2RS	2
16	J209012	Washer M16 Form B	1
17	SP01007	Coach Bolt M6	2
18	SP01016	Button Head M6 X 12	2
19	SP02004	Nut M6 Nyloc	2
20	SP02010	Nut M12 Nyloc	2
21	SP03007	Washer M6 X 18	2
22	SP03012	Washer M12 Form A	2
23	SP03014	Washer M6 Form C	2
25	229191	Shear Blade 22" (0.090")	1
26	SP08002	Seal	2
NOT SHOWN			
-	J20032	Screw Bottom Blade	8

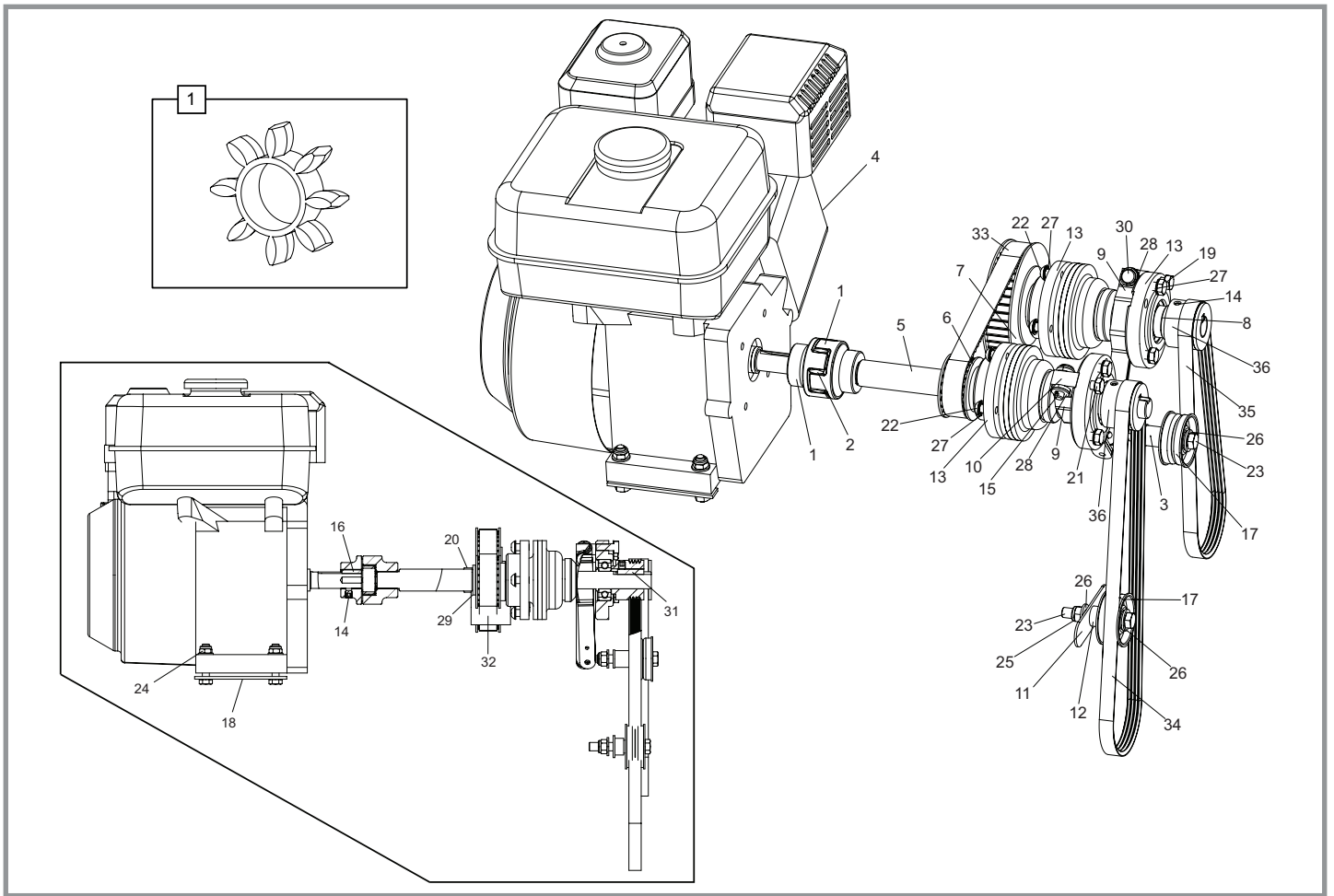

6.01

Engine & Drive Kit - Main Assembly

Item No.	Part No.	Description	Quantity	Item No.	Part No.	Description	Quantity
1	228011	Coupling Half (3/4")	2	34	SP11019	Belt Ribbed 4pk 800	1
2	228103	Coupling Element	1	35	SP11020	Belt Ribbed 4pk 625	1
3	229013	Pulley Spacer	1	36	SP11021	Pulley PK45 4 Rib	2
4	229900	Engine 4.5Hp Honda GX120	1				
5	240007	Drive Shaft	1				
6	240019	Pulley 22-8M-20 6F Finished	1				
7	240020	Pulley 44-8M-20 6F Finished	1				
8	240028	Pulley Spacer	1				
9	240035	Clutch Fork Assy	2				
10	240038	Clutch Pivot Block	2				
11	240088	Slot Blank	1				
12	240089	Spacer Belt Tension Cylinder	1				
13	800208	Clutch Assy*	2				
14	J20467	Grub Screw M8 x 8	4				
15	J209021	Split Pin 1/16" x 1/2"	2				
16	J209029	Key 3/16" x 3/16" x 7/8" Rd End	2				
17	J209047	Tensioner Pulley	2				
18	J209050	Fixing Plate Assy	2				
19	SP01009	Hex Set Screw M8 x 20	6				
20	SP01075	Hex Set Screw M16 x 20	1				
21	SP01045	Hex Set Screw M8 x 25	2				
22	SP01048	Button Head M8 x 16	8				
23	SP01068	Hex Set Screw 3/8" UNF x 2 1/2"	2				
24	SP02006	Nut M8 Nyloc	4				
25	SP02018	Nut 3/8" UNF Nyloc	2				
26	SP03002	Washer 3/8"	5				
27	SP03004	Washer M8 Toothed	14				
28	SP03008	Washer M8 Form A	8				
29	SP03021	Washer M16 Form C	2				
30	SP05006	Clevis Pin 8 x 30	2				
31	SP10005	Key 6 x 6 x 30 Rd End	2				
32	SP11009	Tensioner Roller R18	1				
33	SP11018	Belt Omega 600-8M-20	1				

NOTE

* For Clutch Assembly breakdown, see Section 6.02

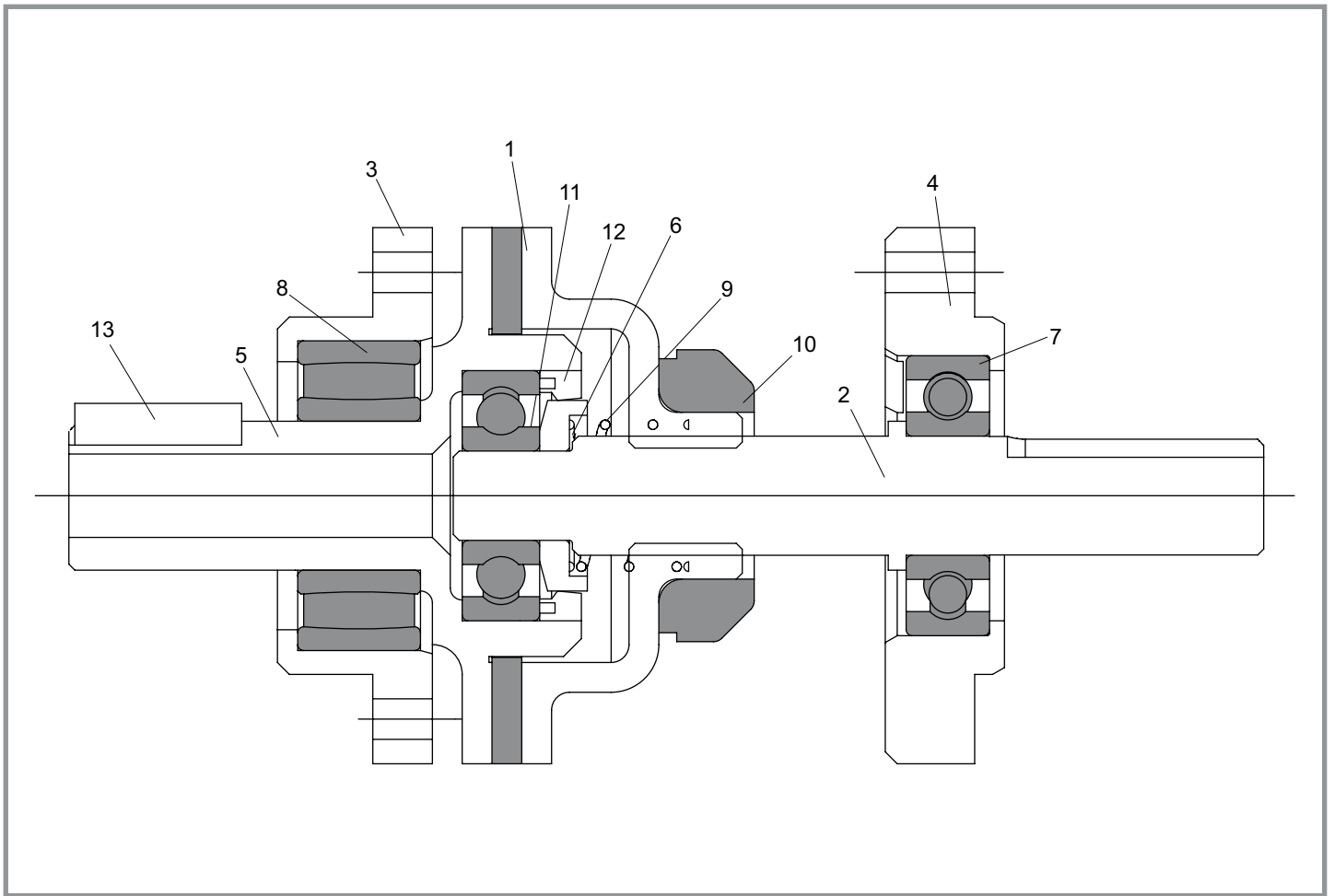

6.02

Engine & Drive Kit - Clutch

Item No.	Part No.	Description	Quantity
1	240011	Clutch Pressure Plate	1
2	240012	Clutch Shaft	1
3	240013	Clutch Bearing Housing	1
4	240016	Clutch Drive Bearing Housing	1
5	240017	Friction Plate Assy	1
6	240018	Clutch Spring Washer	1
7	J20052	Bearing 6204-2RS 3	1
8	J20255	Bearing 5205 - 3205 2RS	1
9	J209246	Top Drive Spring	1
10	SP06005	Bearing Clutch Release	1
11	SP06008	Bearing 6302-2RSL 5C High Temp	1
12	SP08001	Seal Single Lip (42 x 32 x 7 Viton)	1
13	SP10004	Key 8 x 7 x 28	1

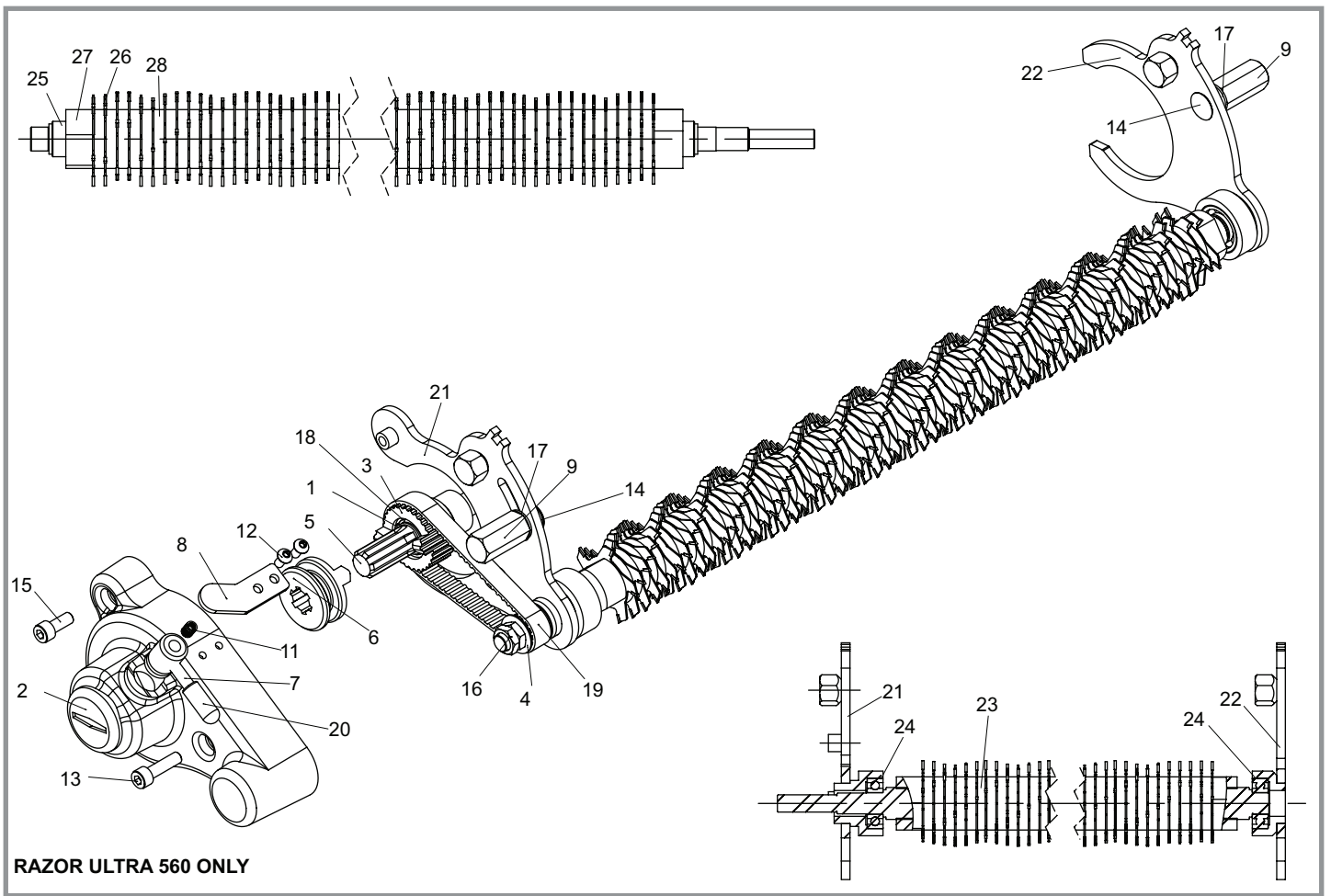

7.01

Groomer Assembly

Item No.	Description	Part Number	Quantity
1	SP07006	Circlip D1400-20	1
2	240110	Groomer Drive	1
3	240111	Pulley 30-5M-25 Finished	1
4	240112	Pulley 15-5M-15 Finished	1
5	240113	Groomer Drive Shaft	1
6	240114	Groomer Actuator	1
7	240117	Groomer Actuator Pin Assy	1
8	240119	Groomer Spring Plate	1
9	240133	Groomer Nut	2
10	800199	Groomer Assy 22"	1
11	J20526	Spring	1
12	SP01016	Button Head M6 x 12	2
13	SP01025	Cap Head M8 x 30	1
14	SP01038	Coach Bolt M8 x 30	2
15	SP01049	Cap Head M8 x 20	1
16	SP02014	Nut M12 Lock (Thin)	2
17	SP03015	Washer M8 Form C	2
18	SP06006	Bush Oilite AI2026 - 25	1
19	SP11014	Belt Omega 325-5M-15	1
20	SP14003	Sleeve Plastic 8mm X 28	1
21	240120	Groomer Plate Assy R.H.	1
22	240130	Groomer Plate Assy L.H.	1
23	800209	Groomer Hob Assy 22"	1
24	SP060001	Bearing 6202-2RSL	2
25	240101	Groomer Shaft (22")	1
26	229771	Groomer Blade	76
27	229794	Locking Collar	2
28	229787	Spacer Sport Groomer	75

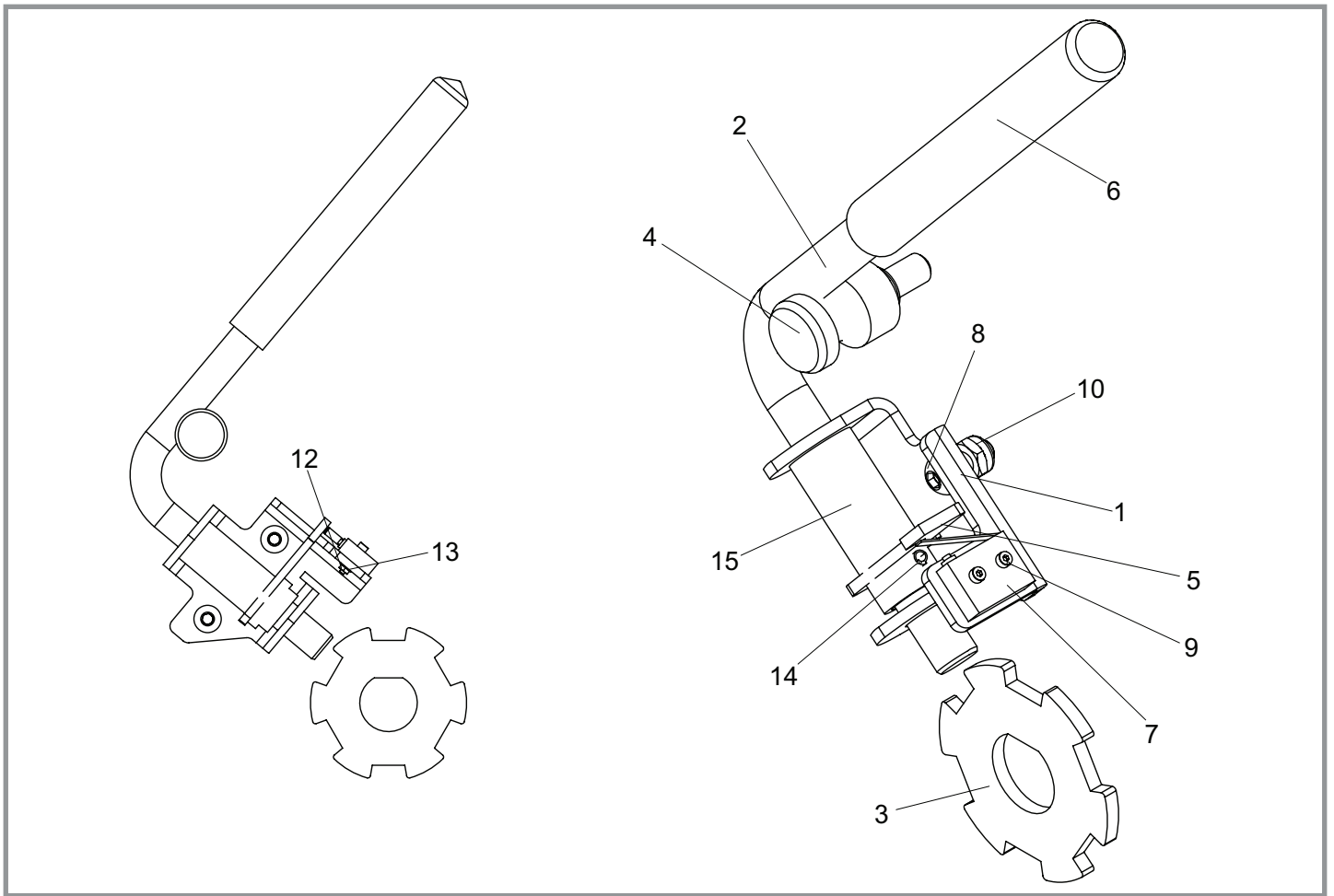

8.01

Brake Assembly

Item No.	Description	Part Number	Quantity
1	240180	Brake Bracket	1
2	240181	Brake Pin	1
3	240182	Brake Disc	1
4	240183	Brake Retainer	1
5	240184	Brake Flag	1
6	J20110	Lever Grip	1
7	SP12005	Micro Switch*	1
8	SP01019	Button Head M6 x 16	2
9	SP01070	Cap Head M2 x 12	2
10	SP02004	Nut M6 Nyloc	2
11	SP02006	Nut M8 Nyloc	1
12	SP02032	Nut M2 Std	2
13	SP03027	Washer M2	2
14	SP05003	Pin Spirol M4 x 22	1
15	SP13003	Spring LC-080J-5	1

NOTE

* Item 7 is part of the Harness

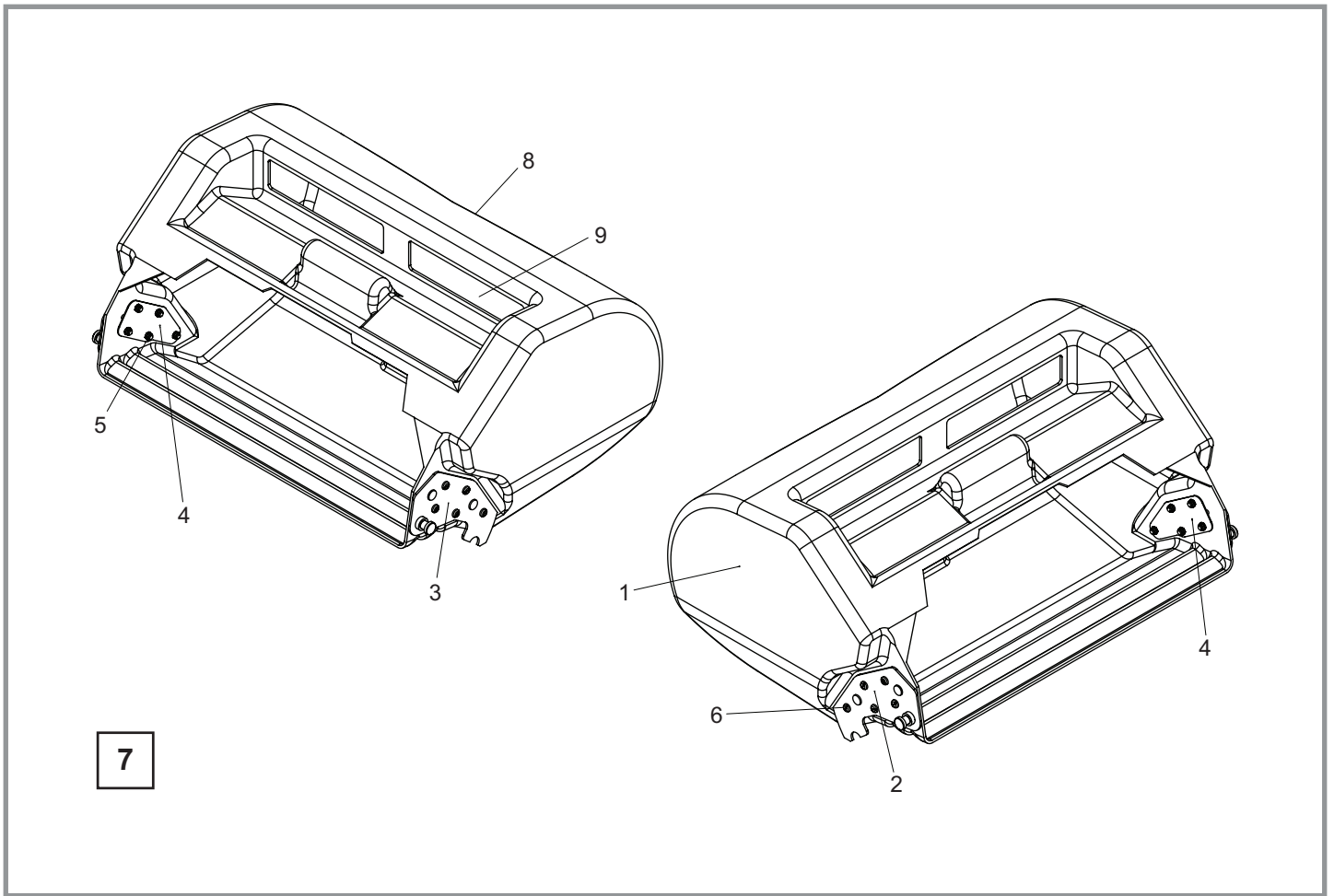

9.01

Grassbox - Main Assembly

Item No.	Part Number	Description	Quantity
1	240200	22" Grass Box (Razor Ultra 560)	1
1	240205	22" Grass Box (Razor 560)	1
2	240201	Grass Box Bracket L.H. W.A.	1
3	240203	Grass Box Bracket R.H. W.A.	1
4	240204	Grass Box Support Plate	2
5	SP02004	Nut M6 Nyloc	10
6	SP04002	Screw M6 x 16 Slotted	10
7	800203	22" Grass Box Assy (Razor Ultra 560)	1
7	800216	22" Grass Box Assy (Razor 560)	1
8	240260	Grass Box Mesh Assembly Front	1
9	240206	Grass Box Mesh Assembly Rear	1

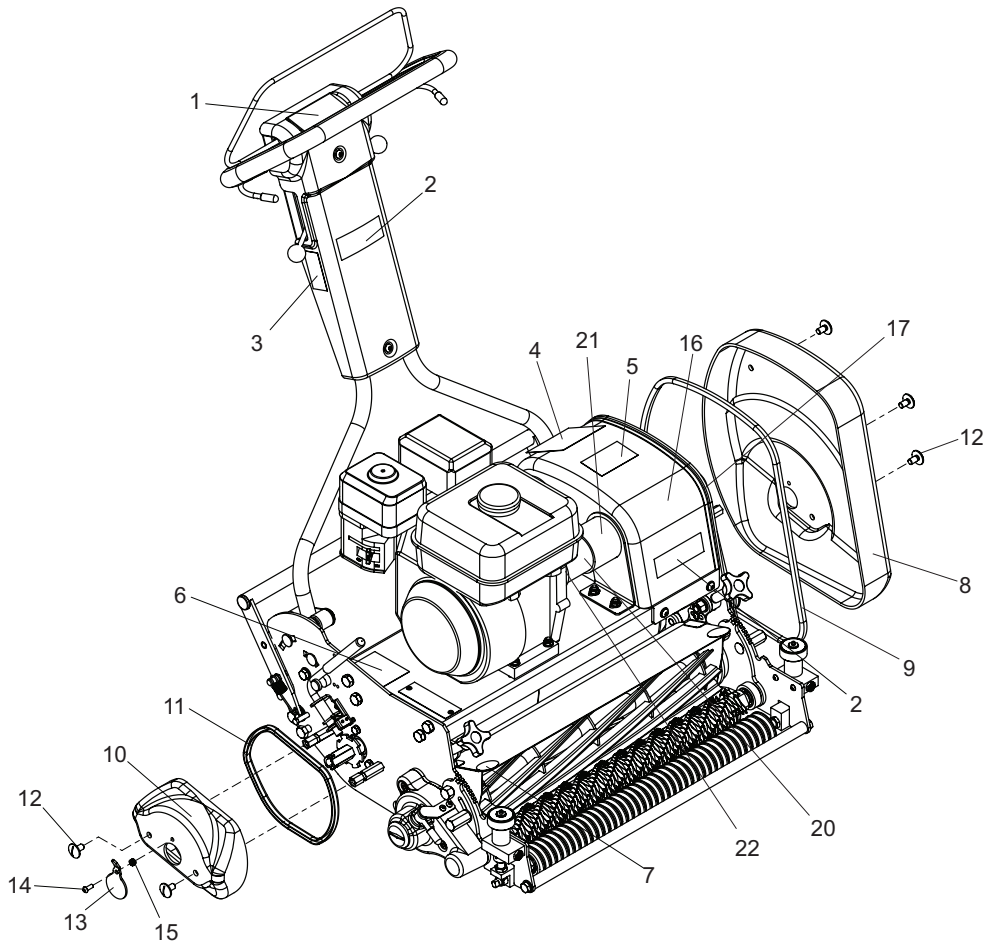

10.01

Guards & Decals

Item No.	Part No.	Description	Quantity
1	SP18002	Decal Drive (Razor)	1
2	J20362	Dennis Decal Small	2
3	SP18003	Decal Cutter (Razor)	1
4	229375	Warning Decal	1
5	1332903	Union Jack Decal	1
6	229603	Parking Brake Decal	1
7	229376	Cut Decal	2
8	240025	Guard Belt	1
9	228031B	Chain Case Seal	1335mm
10	240026	Guard Axle	1
11	228031	Chain Case Seal	620mm
12	194946	Chain Case Screw	5
13	240096	Cover Plate	2
14	SP01019	Button Head M6 x 16	2
15	SP02004	Nut M6 Nyloc	2
16	240021	Clutch Guard Top	1
17	228031C	Chain Case Seal	595mm
20	240175	Shaft Guard	1
21	240190	Guard Support	1
22	240177	Engine Guard Assembly	1

NOT SHOWN

18	SP18001	Decal Throttle (Razor)	1
19	229599	Engine On / Off Decal	1

NOTE

For Handle Guards, See Section 2

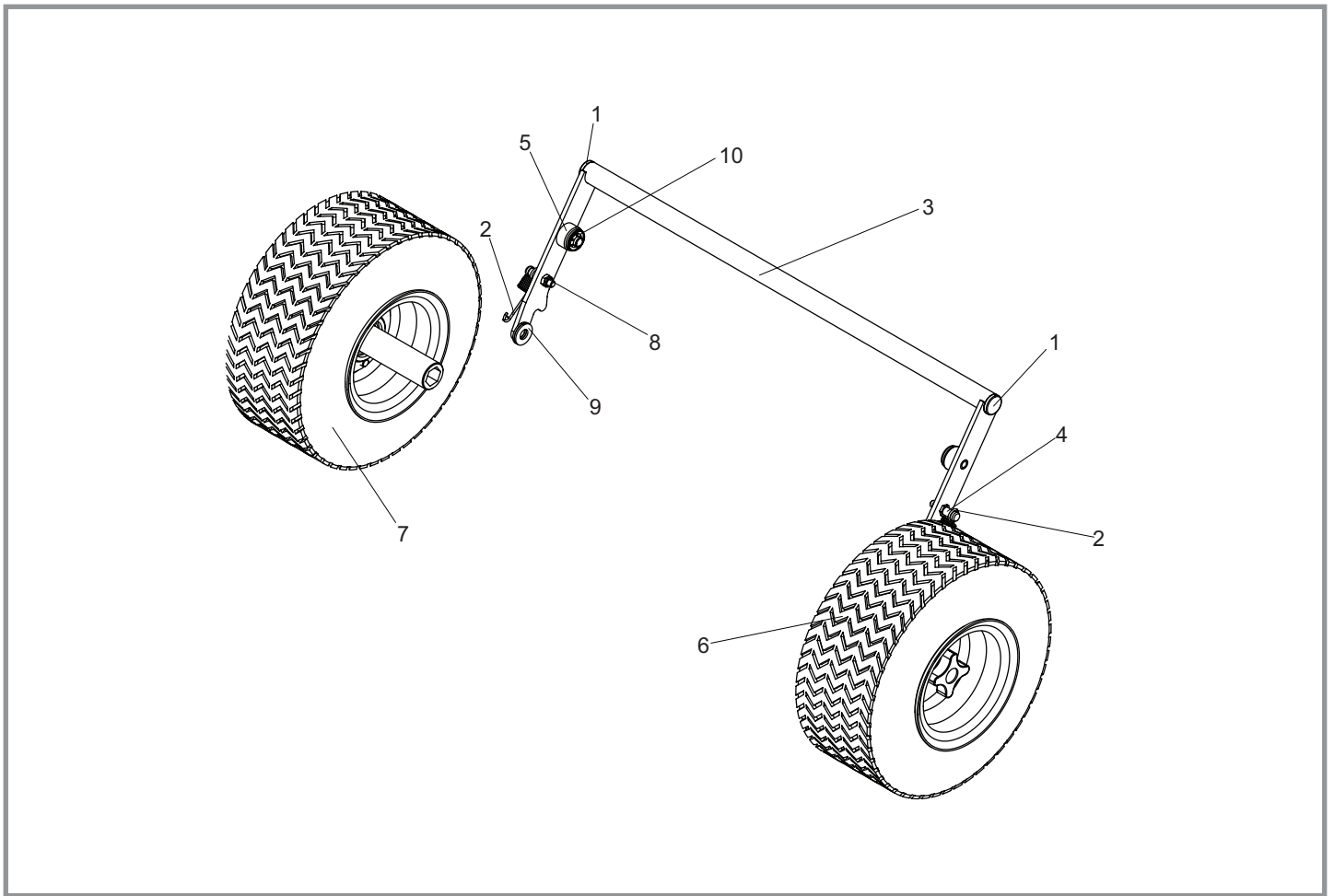

11.01

Wheel Kit - Main Assembly

Item No.	Part No.	Description	Quantity
1	228024	1" Tube Bung	2
2	229167	Clutch Spring	2
3	240160	Stand Transport Wheels	1
4	240164	Stand Spring Pin	2
5	240167	Stand Bush	2
6	800210	Transport Wheel Assy L.H.*	1
7	800211	Transport Wheel Assy R.H.*	1
8	SP02006	Nut M8 Nyloc	2
9	SP03017	Washer M12 Form C	6
10	SP07001	Starlock 12mm	2

NOTE

* For L.H. Transport Assembly breakdown , see Section 11.02

* For R.H. Transport Assembly breakdown , see Section 11.03

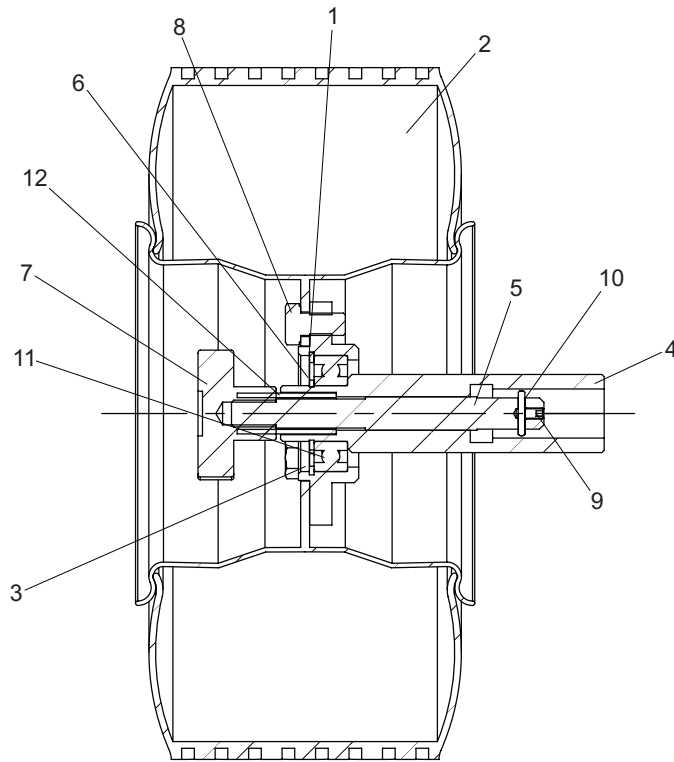

11.02

Wheel Kit - L.H. Wheel

Item No.	Part No.	Description	Quantity
1	228042	Circlip D1300 0520	1
2	240091	Wheel Assy	1
3	240094	Wheel Hub	1
4	240095	Hub Shaft	1
5	240097	Plunger	1
6	J20527	Circlip D1460 - 25	1
7	J209112	Knob Plastic	1
8	SP01034	Hex Set Screw M10 x 20	3
9	SP01051	Grub Screw M5 x 10	1
10	SP05009	Dowel Dia 3 x 20	1
11	SP06011	Bearing CSK25	1
12	SP13003	Spring LC-080J-5	1

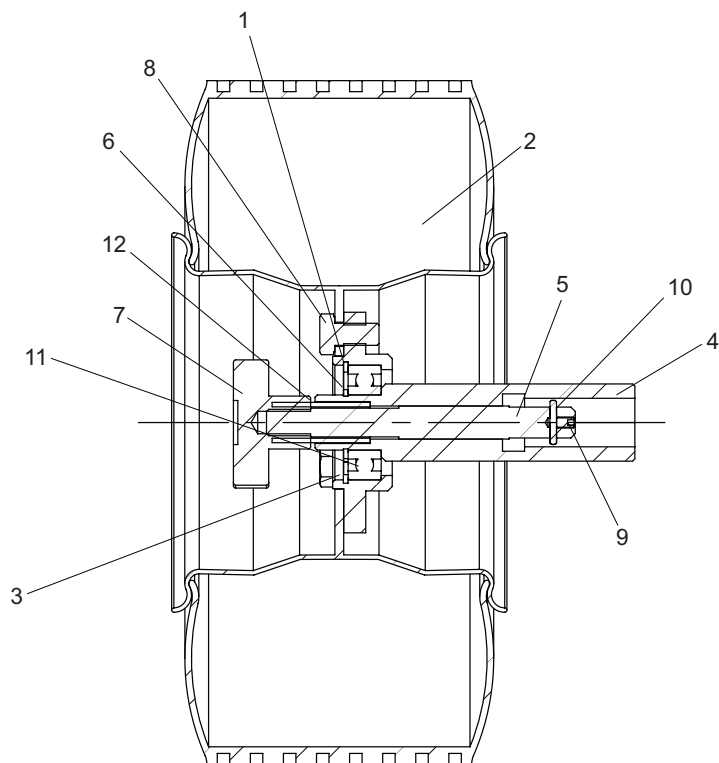

11.03

Wheel Kit - R.H. Wheel

Item No.	Part No.	Description	Quantity
1	228042	Circlip D1300 0520	1
2	240091	Wheel Assy	1
3	240094	Wheel Hub	1
4	240095	Hub Shaft	1
5	240097	Plunger	1
6	J20527	Circlip D1460 - 25	1
7	J209112	Knob Plastic	1
8	SP01034	Hex Set Screw M10 x 20	3
9	SP01051	Grub Screw M5 x 10	1
10	SP05009	Dowel Dia 3 x 20	1
11	SP06011	Bearing CSK25	1
12	SP13003	Spring LC-080J-5	1



DENNIS, Ashbourne Road, Kirk Langley, Derby, DE6 4NJ, United Kingdom

Telephone:- 01332 824777

Fax:- 01332 824 525

E-mail:- sales@dennisuk.com

E-mail:- spares@dennisuk.com

www.dennisuk.com